

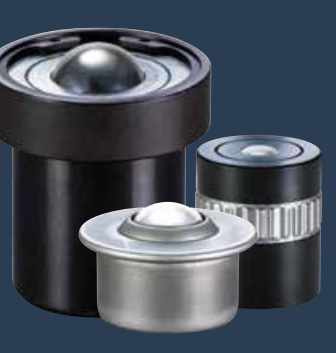

omnitrack[®]
omnidirectional movement

Effortless Precision

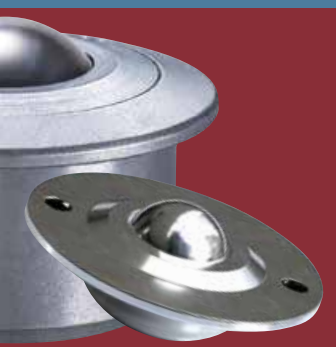

**SINCE
1909**

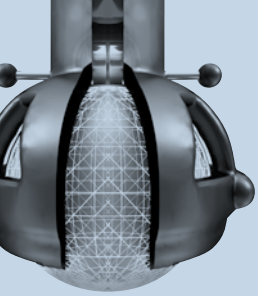

2017

Heavy duty 18000lbs Ball Unit.
New technology & materials

2014

New Omnicaster
Range Launched



2011

"Bloodhound" 1000mph
Land Speed Record
(Product Sponsor)

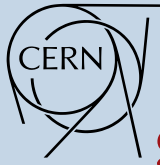

2009

CERN "Hadron" collider
particle research
project supplier



1990

Euro Fighter production
project supplier



1970

Blue Steel nuclear warhead
handling equipment –
design & production



1962

De Havilland Aircraft
landing gear – design
& manufacture contract

1958

1958 Patented "OMNITRACK"
Ball Transfer Units launched



1928

Gravity conveyor rollers, Skatowheels
& live racking systems launched

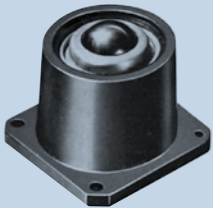

1930

Belt "Linisher"
designed & launched

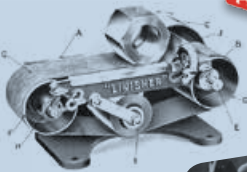

1923

TST "Townsend, Skinner
& Tingle" car produced

1918

"AUTOGLIDER" scooter range
Mass produced & exported

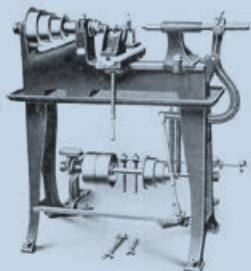

1909

Inception as manufacturer of
Lathes, heavy duty Casters
& Cabinet Drawer Slides



**omnitrack
BALL TRANSFER UNITS**
page 4 - 13

- Heavy Duty load capacity 18,000 lbs/unit
- Low friction 1:0,005 (0.5% of conveyed load)
- Instant & precise directional change
- Resistance to shock impact, temperature & speed

BALL TABLES & PLATFORMS
page 19



Call, email or chat online.
Free technical advice now.



No minimum order charges.
Buy what you need now.



Rapid production of
a custom solution to
meet your needs.



Immediate despatch from
stock & fast global delivery.



Original Patented design, tested &
manufactured in the UK since 1909.

Effortless Precision



omnicaster PLASTIC CASTERS

page 14 - 15

- Easy steering & fast directional change
- Suitable for delicate surfaces
- Self-cleaning in operation
- Large ball projection



omnifloat GLASS HANDLING

page 16

- Ideal for glass & other sheet materials
- Extra hard-wearing & high heat ball upgrade options
- Stainless steel arm upgrade for wet & corrosive conditions



omniwheel CONVEYOR ROLLERS

page 16

- Ideal in outdoor, dusty & 'washdown' areas
- Easy integration within existing conveyor roller systems
- Hexagon drive for powered or 'Plain' center for gravity conveying

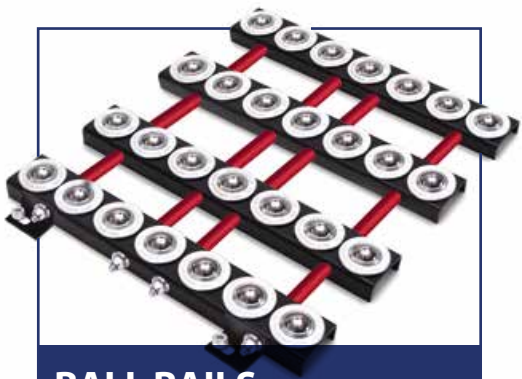

BALL RAILS

page 18



BALL SKATES

page 20



FLEXIBLE CONVEYORS

page 17



▽ = Not applicable on units with Ball Ø 0.5"

Low Friction
1: 0,005

Speed
6 ft/sec

Temperature
-60 to 320 °F

Orientation
ANY

High Shock
Resistance

Drain/Debris
Channels

User
Serviceable

18000 lbs capacity at any angle of orientation

"Endless track" design - smoothest precision

Heavy duty precision machined construction

Service kits & factory spares since 1954

STANDARD MATERIALS - AISI 52100 high chrome steel balls & "Anti-Oxide" electrophoretic coating of machined steel housing.		Corrosion	Contamination	Temperature	Radiation	
18000 lbs LOAD RATINGS UNAFFECTED AT ANY ORIENTATION	Solve specific application requirements by upgrading standard materials - select option below by adding suffix:					
	A STAINLESS STEEL BALLS UPGRADE - (AISI 440C) - "Anti-Oxide" housing & load rating remain as standard.	<input checked="" type="checkbox"/>	<input checked="" type="checkbox"/>	<input checked="" type="checkbox"/>	<input checked="" type="checkbox"/>	
	Z ARDUOUS CONDITIONS UPGRADE - Stainless steel AISI440 balls & internal components. Outer housing & load rating as standard.	<input checked="" type="checkbox"/>	<input checked="" type="checkbox"/>	<input checked="" type="checkbox"/>	<input checked="" type="checkbox"/>	
SS ALL STAINLESS STEEL UPGRADE - Stainless Steel AISI 440 internal parts & balls, AISI 304 housing. Load rating as standard.	<input checked="" type="checkbox"/>	<input checked="" type="checkbox"/>	<input checked="" type="checkbox"/>	<input checked="" type="checkbox"/>		
PB PHENOLIC RESIN BALL OPTION - minimise marking of delicate surfaces. Friction, wear & temperature properties change - consult us if in doubt. Reduced load ratings indicated.						
			BALL Ø (")	0.5	1	1.5+
			PB LOAD (lbs)	22	65	75

90 Series - PLAIN FIT

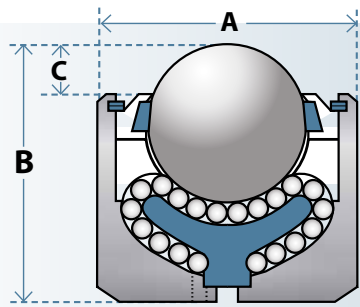

PART	LOAD lbs	BALL Ø	A	B	C
9000	120	1/2"	0.787	0.787	0.156 ♦
9001	120	1/2"	0.812	0.750 *	0.156 ♦
9010	120	1/2"	0.875	0.875	0.156 ♦
9020	500	1"	1.732	1.625	0.219
9021	500	1"	1.750	1.625	0.219
9022	500	1"	1.750	1.625	0.281
9030	850	1"	1.968	1.750	0.250
9031	850	1"	2.0	1.750	0.250
9040	2500	1 1/2"	2.362	2.421	0.500
9041	2500	1 1/2"	2.375	2.421	0.500
9042	2500	1 1/2"	2.375	2.375	0.500
9050	5000	2"	3.937	3.740	0.562
9051	5000	2"	4.0	3.875	0.562
9060	10000	3"	6.297	5.703	0.825
9070	18000	4"	8.969	7.484	1.500

* 9001 has spigot 0.125" x 0.313" dia. ♦ further 0.0625" @ 0.640" outside Ø

Fixing Options - page 11

92 Series - FLANGE MOUNTED

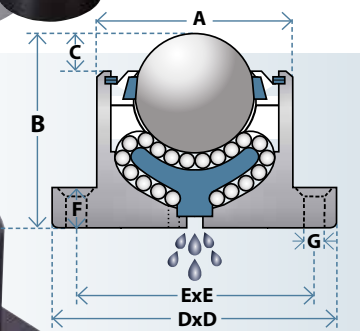

PART	LOAD lbs	BALL Ø	A	B	C	D x D	E x E	F	G Ø
9200	120	1/2"	0.938	0.875	0.156 ~	1.750 Ø ♦	1.375	0.125	2 x 0.141
9210	120	1/2"	0.938	0.875	0.156 ~	1.875 x 1.250 *	1.375	0.078	2 x 0.156 ♦
9220	500	1"	1.734	1.625	0.219	2.250	1.750	0.188	4 x 0.240
9221	500	1"	1.750	1.625	0.281	2.250	1.750	0.188	4 x 0.240
9230	850	1"	1.969	1.750	0.250	3.000	2.281	0.250	4 x 0.319
9240	2500	1 1/2"	2.362	2.422	0.500	3.000	2.281	0.500	4 x 0.319
9241	2500	1 1/2"	2.375	2.375	0.500	3.000	2.281	0.500	4 x 0.319
9250	5000	2"	3.938	3.875	0.562	5.000	4.000	0.375	4 x 0.437 ♦
9260	10000	3"	6.297	5.709	0.825	6.891	5.709	0.590	4 x 0.516
9270	18000	4"	8.969	7.480	1.500	9.250	7.500	0.984	4 x 0.634

♦ 9200 - Circular flange * 9210 - Elliptical flange
~ further 0.059" @ 0.641" outside Ø ♦ Not countersunk



91 Series - *THREADED STUD*

PART	LOAD lbs	BALL Ø	A	B	C	D	E	F
9100	120	1/2"	0.787	0.750	0.156 *	0.640		M8 x 1.25
9101	120	1/2"	0.812	0.750	0.156 *	1.125		M8 x 1.25
9102	120	1/2"	0.812	0.750	0.156 *	1.125		5/16" UNF
9112	120	1/2"	0.875	0.875	0.156 *	1.000		5/16" UNF
9120	500	1"	1.734	1.902	0.219	0.984		M12 x 1.75
9123	500	1"	1.734	1.859	0.219	0.984	0.236	M12 x 1.75
9124	500	1"	1.750	1.859	0.281	1.000	0.236	1/2" UNF
9130	850	1"	1.969	2.016	0.250	0.984		M12 x 1.75
9133	850	1"	1.969	1.984	0.250	0.984	0.236	M12 x 1.75
9134	850	1"	2.000	1.984	0.250	1.000	0.236	1/2" UNF
9135	850	1"	2.000	1.656	0.250	2.362	0.390	1" UNF
9140	2500	1 1/2"	2.362	2.891	0.500	1.578		M20 x 2.5
9143	2500	1 1/2"	2.362	2.813	0.500	1.578	0.390	M20 x 2.5
9144	2500	1 1/2"	2.375	2.813	0.500	1.500	0.390	3/4" UNF
9145	2500	1 1/2"	2.375	2.359	0.500	2.953	0.236	1" UNF
9150	5000	2"	3.937	4.134	0.562	2.126		M24 x 3.0
9153	5000	2"	3.937	4.296	0.562	1.969	0.421	M24 x 3.0
9154	5000	2"	4.000	4.296	0.562	2.000	0.421	1" UNF
9160	10000	3"	6.297	5.703	0.828	2.250		1" UNF
9163	10000	3"	6.297	5.703	0.828	3.937	0.590	M30 x 3.5

* further 0.059" @ 0.641" outside Ø

91 Series units omit drain/debris channel - contact us if required

91 SERIES
ENDING 0, 1, 2 & 5



91 SERIES
ENDING 3 & 4

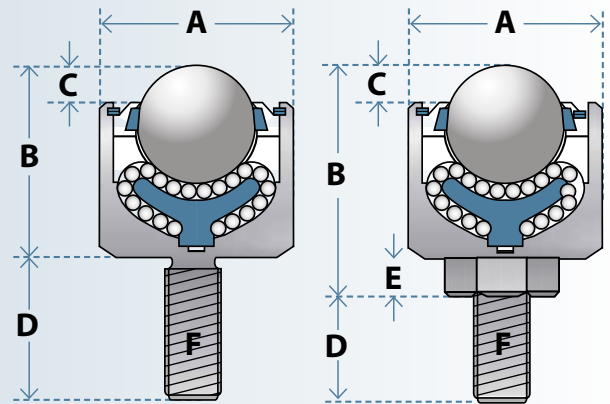

93 Series - *FLANGE SOCKET*

PART	LOAD lbs	BALL Ø	A	B	C	D x D	E x E	F	G Ø
9300	120	1/2"	0.937	0.875	0.438	1.750 ø ♦	1.375	0.125	2 x 0.141
9310	120	1/2"	0.937	0.875	0.313	1.875 x 1.250 *	1.375	0.078	2 x 0.156 ◊
9320	500	1"	1.734	1.625	0.406	2.250	1.750	0.188	4 x 0.240
9321	500	1"	1.750	1.625	0.469	2.250	1.750	0.188	4 x 0.240
9330	850	1"	1.969	1.750	0.500	3.000	2.281	0.250	4 x 0.319
9341	2500	1 1/2"	2.363	2.363	1.000	3.000	2.281	0.500	4 x 0.319
9350	5000	2"	3.937	3.740	1.313	5.000	4.000	0.750	4 x 0.437
9351	5000	2"	4.000	3.875	1.437	5.000	4.000	0.875	4 x 0.437
9352	5000	2"	4.313	3.875	1.313	5.000	4.000	0.750	4 x 0.406 ◊
9360	10000	3"	6.297	5.709	1.417	6.890	5.709	0.594	4 x 0.516

♦ 9300 - Circular flange * 9310 - Elliptical flange
◊ Not countersunk

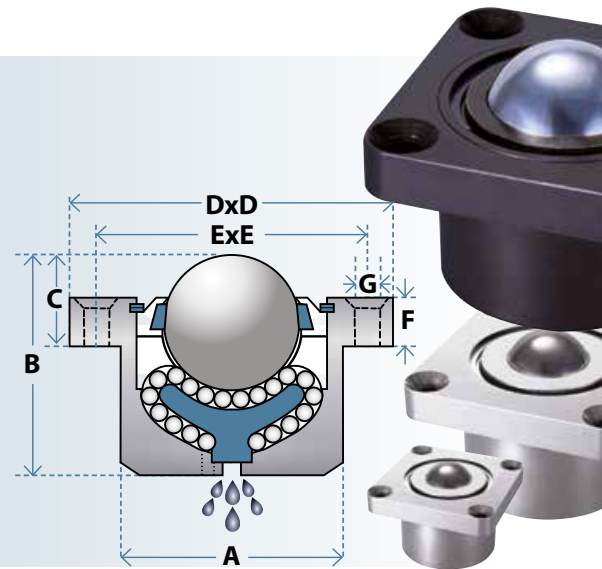

98 Series - *TOLERANCE RING*

PART	LOAD lbs	BALL Ø	A	B	C	D	E	F
9810	120	1/2"	0.866 *	0.472	0.234	0.828	0.945	0.094
9820	500	1"	1.772 *	0.594	0.551	1.578	1.929	0.272
9830	850	1"	1.969 *	0.630	0.591	1.734	2.165	0.339
9840	2500	1 1/2"	2.559 *	0.787	0.984	2.362	2.756	0.484
9850	5000	2"	3.937 *	0.945	1.181	3.750	4.331	0.618

* Bore Ø to ISO H9 fit

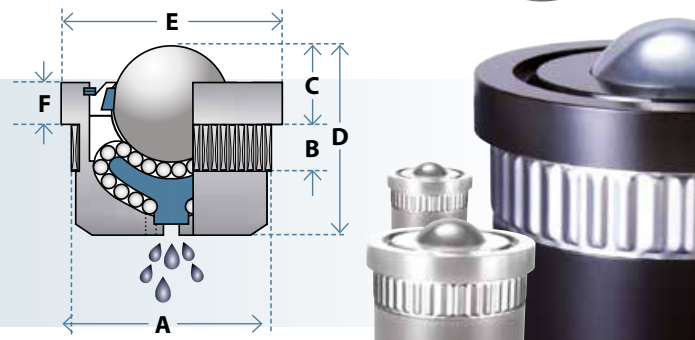

▼ = Not applicable on units with Ball Ø 0.5"

Low Friction 1: 0,005 	Speed 6 ft/sec 	Temperature -22 to 320°F 	Orientation ANY 	High Shock Resistance 	Uneven Loads 	Factory Refurbishment 
--	---	---	--	--	--	---

Springs resist shock impact & misaligned loads
'Endless track' - smoothest precision at any angle

Uneven track conditions - springs self adjust
Heavy duty precision machined construction

STANDARD MATERIALS - AISI 52100 high chrome steel balls & "Anti-Oxide" electrophoretic coating of machined steel housing. Spring mechanism parts in carbon spring steel irrespective of material upgrade options below.





18000 lbs



LOAD RATINGS UNAFFECTED AT ANY ORIENTATION

Solve specific application requirements by upgrading standard materials - select option below by adding suffix:

A	STAINLESS STEEL BALLS UPGRADE - AISI 440C "Anti-Oxide" housing & load rating remain as standard.
Z	ARDUOUS CONDITIONS UPGRADE - Stainless Steel AISI440 internal parts & balls. "Anti-Oxide" electrophoretic outer casing & carbon steel spring mechanism. Spring values & load ratings as standard.
SS	ALL STAINLESS STEEL UPGRADE - Stainless steel AISI304 housing. Balls & Internal parts AISI 440. Spring values & load ratings as standard.

	Corrosion	Contamination	Temperature	Radiation
				
A	✓	✓	✓	✓
Z	✓✓	✓✓	✓✓	✓
SS	✓✓✓	✓✓✓	✓✓✓	✓✓✓

94 Series - EXTERNAL SPRING LOADED



PART	BALL Ø	PRE-LOAD lbs	MAX DEFLECTION ADVISED	LOAD AT MAX DEFLECTION lbs	A	B	C	D	E	FIXING HOLES (PCD)	G
9401	1/2"	15	0.080	70	0.812	1.266	1.859	0.581	0.787		0.156 ~
9402	1/2"	30	0.080	77	0.812	1.250	1.859	0.581	0.787		0.156 ~
9403	1/2"	50	0.080	84	0.812	1.266	1.859	0.581	0.787		0.156 ~
9404	1/2"	50	0.080	84	0.787	1.266	1.859	0.581	0.787		0.156 ~
9410	1/2"	15	0.080	70	0.875	1.535	1.859	0.581	0.787		0.156 ~
9411	1/2"	30	0.080	77	0.875	1.516	1.859	0.581	0.787		0.156 ~
9412	1/2"	50	0.080	84	0.875	1.531	1.859	0.581	0.787		0.156 ~
9420	1"	15	0.213	300	1.750	2.437	3.031	0.750	1.250	3 x M5 @ 0.969	0.219
9421	1"	50	0.197	300	1.750	2.422	3.031	0.750	1.250	3 x M5 @ 0.969	0.219
9422	1"	100	0.172	300	1.750	2.398	3.031	0.750	1.250	3 x M5 @ 0.969	0.219
9423	1"	150	0.209	300	1.750	2.433	3.031	0.750	1.250	3 x M5 @ 0.969	0.219
9424	1"	200	0.109	450	1.750	2.422	3.031	0.750	1.250	3 x M5 @ 0.969	0.219
9425	1"	240	0.102	450	1.734	2.484	3.031	0.750	1.250	3 x M5 @ 0.969	0.219
9430	1"	200	0.303	730	2.000	3.181	3.750	0.750	1.500	3 x M6 @ 1.142	0.250
9431	1"	300	0.250	730	2.000	3.134	3.750	0.750	1.500	3 x M6 @ 1.142	0.250
9432	1"	400	0.228	730	2.000	3.169	3.750	0.750	1.500	3 x M6 @ 1.142	0.250
9433	1"	500	0.181	730	2.000	3.188	3.750	0.750	1.500	3 x M6 @ 1.142	0.250
9440	1 1/2"	500	0.413	2116	2.375	4.528	6.382	1.375	2.339	3 x M6 @ 2.0	0.500
9441	1 1/2"	700	0.438	2116	2.375	4.766	6.382	1.375	2.339	3 x M6 @ 2.0	0.500
9442	1 1/2"	1000	0.438	2116	2.375	5.087	6.382	1.375	2.339	3 x M6 @ 2.0	0.500
9443	1 1/2"	1250	0.344	2116	2.375	5.000	6.382	1.375	2.339	3 x M6 @ 2.0	0.500
9444	1 1/2"	1500	0.359	2116	2.375	5.760	7.469	1.375	2.339	3 x M6 @ 2.0	0.500
9445	1 1/2"	1650	0.323	2116	2.375	6.156	7.469	1.375	2.339	3 x M6 @ 2.0	0.500
9450	2"	1680	0.080	3086	4.000	5.476	6.312	2.000	4.000	4 x M8 @ 3.0	0.563
9451	2"	1680	0.209	3086	4.000	6.891	7.906	2.244	4.000	4 x M8 @ 3.0	0.563
9452	2"	2245	0.234	3086	4.000	6.984	7.906	2.244	4.000	4 x M8 @ 3.0	0.563
9453	2"	2800	0.234	3968	4.000	6.875	7.906	2.244	4.000	4 x M8 @ 3.0	0.563
9454	2"	3000	0.098	4409	4.000	5.390	6.234	2.000	4.000	4 x M8 @ 3.0	0.563
9455	2"	3370	0.225	4488	4.000	6.750	7.906	2.244	4.000	4 x M8 @ 3.0	0.563

~ further 0.059" @ 0.641" outside ø

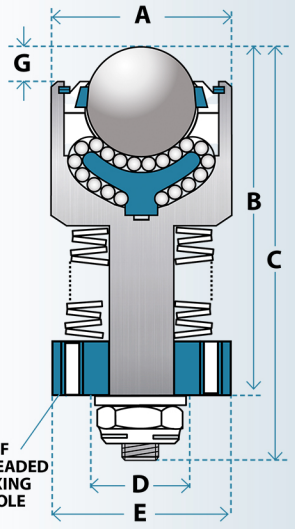



T-BARS & B-BARS

'T' & 'B' Bars incorporate Heavy Duty spring-loaded ball units for accurate positioning & effortless conveying of tools & dies on press & machine beds. Once positioned, clamp the tool & the springs allow the ball units to retract beneath the bed. Unclamp & the ball units will raise the tool above the bed ready to convey again. 'T' bars feature an integral locking mechanism - 'B' bars are locked using recessed M8 cap screw (requires drilling & tapping of the bed). Custom sizes available.

BAR	A	B	C	D	BAR LENGTH inches	SUPPORTS LOAD/BAR lbs	DEFLECTION inch	LOAD AT MAX DEFLECTION lbs	BALL/BAR
T-20	0.787	1.339	0.390	1.375	11.813	494	0.102	776	8
T-22	0.866	1.453	0.625	1.500	13.500	556	0.102	873	9
T-24	0.945	1.656	0.709	1.656	16.344	617	0.102	970	10
T-28	1.102	1.812	0.787	1.890	12.000	679	0.102	1067	11
T-36	1.417	2.205	0.984	2.406	13.593	556	0.102	873	9
B-21	0.812			1.000	9.844	370	0.102	582	6
B-22	0.875			1.184	15.562	494	0.102	776	8
B-25	1.000			1.500	13.781	672	0.102	1067	11

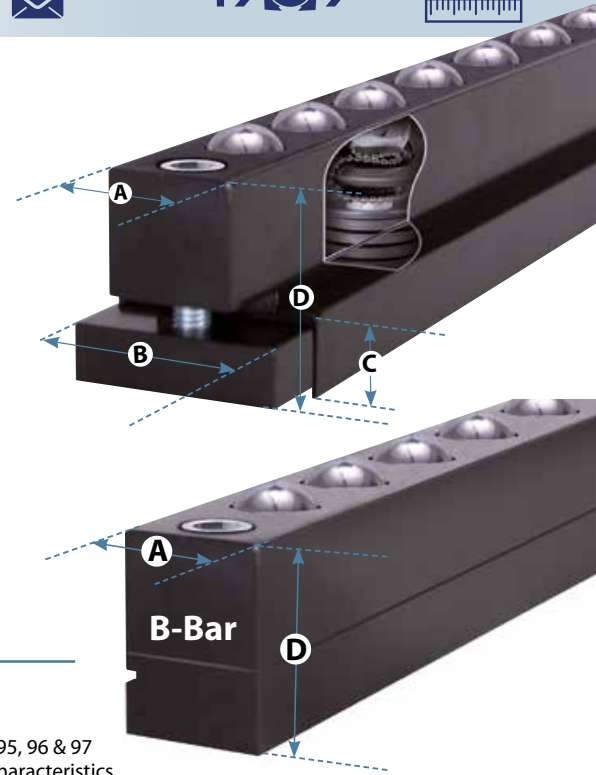

SPRING LOADED 94, 95, 96 & 97 SERIES

Omnitrack Heavy Duty spring loaded units are ideal where uneven track conditions or shock loading occurs. 95, 96 & 97 Series offer full retraction of the ball within the housing. We can easily tailor spring pre-loads, deflections & characteristics to your requirements. Consider alternative material upgrade options to withstand severe operating environments.

95 Series - HOUSED SPRING LOADED

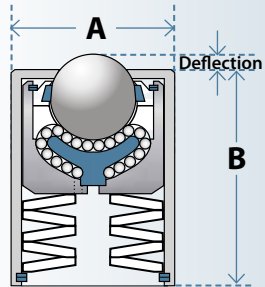

PART	SUPPORTS LOAD lbs	DEFLECTION inch	LOAD AT MAX DEFLECTION lbs	BALL Ø	A	B
9500	50	0.087	84	1/2"	1.0 *	1.000
9501	26	0.125	101	1/2"	1.0 *	1.000
9520	200	0.188	414	1"	2.000	2.188
9530	500	0.094	809	1"	2.500	2.375
9540	992	0.391	2116	1 1/2"	2.750	4.500
9550	2200	0.240	4409	2"	4.719	5.468

* 0.313" wide (fine) knurl on outside Ø



96 Series - FLANGE SOCKET SPRING LOADED

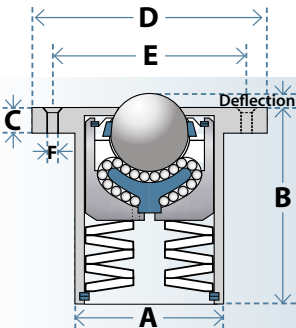

PART	SUPPORTS LOAD lbs	DEFLECTION inch	LOAD AT MAX DEFLECTION lbs	BALL Ø	A	B	C	D	E (PCD)	F COUNTER-SUNK
9601	26	0.125	101	1/2"	1.000	1.000	0.197	1.969	1.422	2 x 0.203
9620	200	0.188	414	1"	2.000	2.188	0.234	3.150	2.563	3 x 0.234
9630	500	0.094	809	1"	2.500	2.375	0.234	3.938	3.156	3 x 0.313
9640	992	0.391	2116	1 1/2"	2.750	4.500	0.391	4.531	3.625	3 x 0.398
9650	2200	0.240	4409	2"	4.719	5.468	0.472	6.500	5.516	3 x 0.398



97 Series - FLANGE MOUNTED SPRING LOADED

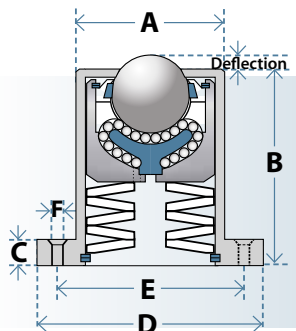

PART	SUPPORTS LOAD lbs	DEFLECTION inch	LOAD AT MAX DEFLECTION lbs	BALL Ø	A	B	C	D	E (PCD)	F COUNTER-SUNK
9701	26	0.125	101	1/2"	1.000	1.000	0.197	1.969	1.422	2 x 0.203
9720	200	0.188	414	1"	2.000	2.188	0.234	3.150	2.563	3 x 0.234
9730	500	0.094	809	1"	2.500	2.375	0.234	3.938	3.156	3 x 0.313
9740	992	0.391	2116	1 1/2"	2.752	4.500	0.391	4.531	3.622	3 x 0.398
9750	2200	0.240	4409	2"	4.719	5.468	0.472	6.500	5.516	3 x 0.398

MEDIUM DUTY RANGE



Low Friction
1: 0,02

Speed
3 ft/sec

Temperature
-22 to 212 °F

Orientation
Horizontal/
ball up

Shock Resistance

Medium Duty ball units are machined from solid steel & case hardened for wear resistance. Reinforced machined steel top cap protect against impact from misalignment of the conveyed item. Lubricated for life & zinc plated for resistance to corrosion. Standard materials; Body & cap AISI 1015, Balls AISI 52100. Stainless steel upgrade 'A' & 'SS' feature AISI420 balls & body. Main ball sizes ≥ 0.750 " incorporate a felt seal to minimise contamination. 'M', 'MG' & 'MS' Series feature a single drain hole.

M Series - PUSH FIT

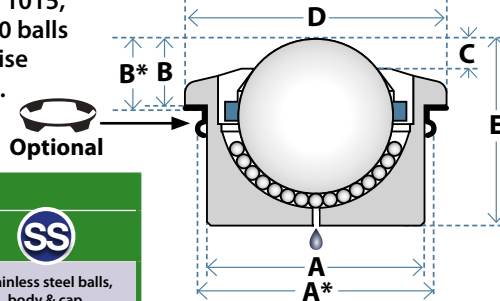

MAXIMUM LOAD CAPACITY & NETT WEIGHT lbs																
PART	STANDARD		A		D		SS		Ball Ø	A	A*	B	B*	C	D	E
	LOAD	WEIGHT	LOAD	WEIGHT	LOAD	WEIGHT	LOAD	WEIGHT								
M12 *	55	0.084	44	0.084	11	0.068	44	0.084	1/2"	0.866		0.315		0.126	1.063	0.657
M14	132	0.117	110	0.117	22	0.086	88	0.112	5/8"	0.945	0.984 - 1.004	0.319	0.331	0.197	1.181	0.787
M15 *	132	0.130	110	0.130	22	0.097	88	0.128	5/8"	0.945	0.984 - 1.004	0.374	0.386	0.157	1.220	0.827
M22	397	0.417	397	0.414	44	0.331	278	0.414	7/8"	1.417	1.457 - 1.465	0.386	0.398	0.150	1.772	1.201
M25 *	441	0.425	309	0.423	55	0.302	309	0.423	1"	1.496		0.551		0.236	1.772	1.187
M30	772	0.794	772	0.787	55	0.611	485	0.787	1 3/16"	1.772	1.823 - 1.839	0.543	0.552	0.228	2.165	1.449
M45	1323	2.227	1323	2.205	55	1.565	772	2.249	1 3/4"	2.441	2.480 - 2.500	0.748	0.760	0.354	2.953	2.106
M60	3307	8.180	2425	8.422	NA	NA	2315	8.444	2 3/8"	3.937		1.181		0.591	4.606	3.051

* Denotes pressed top cap. When using K clips dimensions A & B change to A* & B*



MF Series - BOTTOM FLANGE

MAXIMUM LOAD CAPACITY & NETT WEIGHT lbs																
PART	STANDARD		A		D		BALL Ø	A	B	C	D	ExE	Fx F	G	H	
	LOAD	WEIGHT	LOAD	WEIGHT	LOAD	WEIGHT										
MF12 *	55	0.227	44	0.227	11	0.220	1/2"	0.941	0.813	0.677	0.138	1.750 #	1.375	0.125	2 x 0.141	
MF15 *	132	0.108	110	0.106	22	0.196	5/8"	0.945	0.825	0.630	0.197	1.772	1.260	0.188	4 x 0.181	
MF22	397	0.390	397	0.567	44	0.483	7/8"	1.417	1.201	1.023	0.177	2.250	1.750	0.188	4 x 0.219	
MF30	772	1.105	772	1.111	55	0.917	1 3/16"	1.772	1.449	1.193	0.256	3.000	2.281	0.250	4 x 0.281	
MF45	1323	2.509	1323	2.575	55	2.046	1 3/4"	2.441	2.106	1.772	0.335	3.346	2.717	0.250	4 x 0.281	

MF12 has a 1.75" ø circular flange with 2 mounting holes * Denotes pressed top cap.

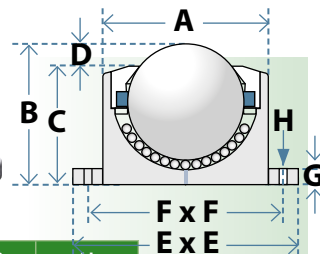

MS Series - TOP FLANGE

MAXIMUM LOAD CAPACITY & NETT WEIGHT lbs																
PART	STANDARD		A		D		BALL Ø	A	B	C	DxD	ExE	F	G		
	LOAD	WEIGHT	LOAD	WEIGHT	LOAD	WEIGHT										
MS12 *	55	0.227	44	0.220	11	0.220	1/2"	0.941	0.378	0.437	1.750 #	1.375	0.125	2 x 0.141		
MS15 *	132	0.130	110	0.130	22	0.097	5/8"	0.945	0.445	0.382	1.772	1.260	0.188	4 x 0.181		
MS22	397	0.417	397	0.414	44	0.331	7/8"	1.417	0.465	0.736	2.250	1.750	0.188	4 x 0.219		
MS30	772	0.794	772	0.787	55	0.611	1 3/16"	1.772	0.661	0.787	3.000	2.281	0.250	4 x 0.281		
MS45	1323	2.227	1323	2.205	55	1.565	1 3/4"	2.441	0.866	1.240	3.346	2.717	0.375	4 x 0.281		

MS12 has a 1.750" ø circular flange with 2 mounting holes * Denotes pressed top cap.

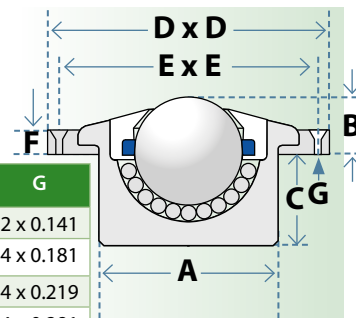

MG Series - PLAIN FITTING

PART	MAXIMUM LOAD CAPACITY & NETT WEIGHT lbs						BALL Ø	*Dimension A changes when using fixing clips (p11)			
	STANDARD		A		D			A	B	C	D
	LOAD	WEIGHT	LOAD	WEIGHT	LOAD	WEIGHT					
MG8*	29	0.037	22	0.040	11	0.036	5/16"	0.709	0.472	0.394	0.079
MG10	55	0.062	44	0.062	11	0.049	1/2"	0.787	0.650	0.531	0.118
MG12*	55	0.077	44	0.075	11	0.060	1/2"	0.866	0.689	0.551	0.138
MG15	132	0.108	110	0.106	22	0.077	5/8"	0.945	0.787	0.591	0.197
MG22	397	0.390	397	0.392	44	0.309	7/8"	1.417	1.201	1.023	0.177
MG30	772	0.739	772	0.745	55	0.551	1 3/16"	1.772	1.449	1.193	0.256
MG45	1323	2.072	1323	2.138	55	1.609	1 3/4"	2.441	2.106	1.772	0.335
MG60	3307	8.047	2425	7.915	NA	NA	2 3/8"	3.937	3.051	2.402	0.650
MG76	5512	18.960	3748	18.960	NA	NA	3"	5.118	4.055	3.150	0.906
MG90	7716	24.934	5291	24.934	NA	NA	3 1/2"	5.709	4.528	3.543	0.984

* Denotes pressed top cap.

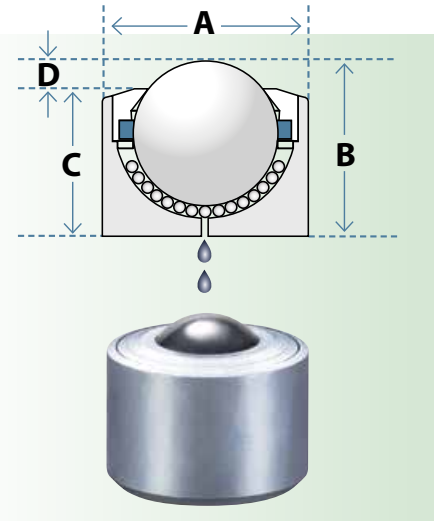

MI Series - INTERNAL THREAD FIXING

PART	MAXIMUM LOAD CAPACITY & NETT WEIGHT lbs						BALL Ø	A	B	C	D	E	F
	STANDARD		A		D								
	LOAD	WEIGHT	LOAD	WEIGHT	LOAD	WEIGHT							
MI12*	55	0.110	44	0.110	11	0.095	1/2"	0.866	0.945	0.807	0.138	M8 x 1.25	0.197
MI15	132	0.163	110	0.163	22	0.134	5/8"	0.945	1.102	0.906	0.197	M8 x 1.25	0.315
MI22	397	0.560	397	0.564	44	0.463	7/8"	1.417	1.594	1.417	0.177	M8 x 1.25	0.394
MI30	772	1.014	772	0.992	55	0.794	1 3/16"	1.772	1.843	1.528	0.315	M8 x 1.25	0.394
MI45	1323	2.601	1323	2.579	55	2.094	1 3/4"	2.441	2.500	1.988	0.512	M8 x 1.25	0.394

* Denotes pressed top cap.

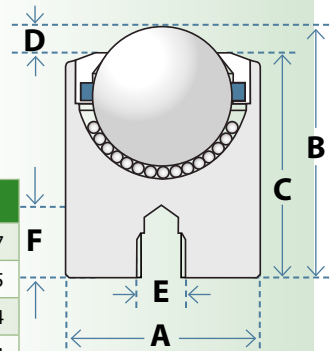

MSP Series - BOLT FITTING

PART	MAXIMUM LOAD CAPACITY & NETT WEIGHT lbs						BALL Ø	A	B	C	D	E	F
	STANDARD		A		D								
	LOAD	WEIGHT	LOAD	WEIGHT	LOAD	WEIGHT							
MSP8	29	0.046	18	0.046	7	0.042	5/16"	0.709	1.063	0.472	0.079	0.591	M6 x 1.0
MSP10	55	0.079	44	0.079	11	0.068	1/2"	0.787	1.173	0.701	0.118	0.472	M8 x 1.25
MSP11	55	0.097	44	0.095	11	0.088	1/2"	0.787	1.890	0.787	0.118	1.102	M6 x 1.0
MSP12*	55	0.086	44	0.086	11	0.086	1/2"	0.866	1.673	0.886	0.138	0.787	M8 x 1.25
MSP14	132	0.121	110	0.143	22	0.093	5/8"	0.945	1.280	0.807	0.154	0.472	M6 x 1.0
MSP15	132	0.183	110	0.183	22	0.152	5/8"	0.984	1.811	1.024	0.197	0.787	M8 x 1.25
MSP19	165	0.240	121	0.249	44	0.194	3/4"	1.181	1.831	1.024	0.189	0.807	M8 x 1.25
MSP22	397	0.564	397	0.564	44	0.441	7/8"	1.417	2.476	1.476	0.177	1.000	M12 x 1.75
MSP30	772	0.970	772	0.948	55	0.763	1 3/16"	1.772	2.724	1.724	0.256	1.000	M12 x 1.75
MSP45	1323	2.998	1323	2.976	55	2.425	1 3/4"	2.441	4.224	2.598	0.335	1.626	M20 x 2.5

* Denotes pressed top cap.

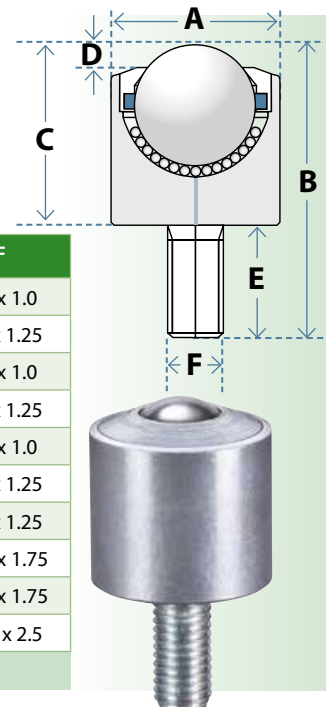



Low Friction
1: 0,02



Speed
3 ft/sec



Temperature
-22 to 212 °F



Orientation
Horizontal/
ball up



Shock
Resistance

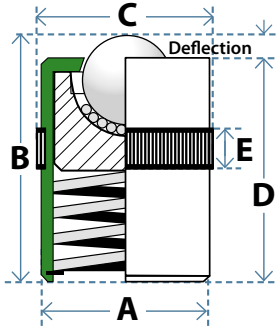

MN/MM Series - HOUSED SPRING LOADED

PART	SUPPORTS LOAD lbs	DEFLECTION inch	LOAD AT MAX DEFLECTION lbs	BALL Ø	A	B	C	D	E
MN12	88	0.060	198	1/2"	0.941	1.181	0.965	1.122	0.413
MN16	132	0.060	243	5/8"	1.177	1.417	1.201	1.358	0.413
MN25	220	0.060	386	1"	1.567	1.890	1.594	1.831	0.413
MN30	739	0.060	1290	1 3/16"	1.965	2.362	1.988	2.303	0.484



STAINLESS STEEL BALL UPGRADE.

= Improved corrosion resistance with no change in load or spring values - add suffix 'A'

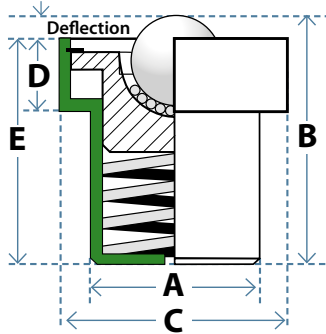

PART	SUPPORTS LOAD lbs	DEFLECTION inch	LOAD AT MAX DEFLECTION lbs	BALL Ø	A	B	C	D	E
MM22	154	0.177	198	7/8"	1.535	2.283	1.969	0.551	2.106
MM30	298	0.276	375	1 3/16"	1.909	2.756	2.441	0.689	2.480
MM45	507	0.413	639	1 3/4"	2.618	3.957	3.346	1.004	3.543

Alternative spring-loaded solutions – page 6 & 7.



MV, MX & MW AIR CARGO BALL UNITS

MV, MX & MW Air Cargo Ball Units

Compliant with ISO Air cargo industry standards these units utilise stainless steel (AISI 420) balls recirculating within a precision machined Steel (AISI 1015) housing. All models feature fluid drain & omit felt seal. Consult page 11 for C-type (stainless steel) & K-type (spring steel) optional fixing clips.

Series	High Temperature	Load & Shock	Low Noise	Corrosion Resistance	Construction options (Add suffix)
MV	✓✓	✓✓	✓✓✓	✓✓	E Lightweight construction
MX	✓✓	✓✓	✓✓	✓	SS Stainless Steel
MW	✓	✓	✓	✓✓✓	SL Stainless Liner Cup

MV 'Imperial' Series – integral moulded scraper cap reduces weight & noise levels during operation. Compact inch series dimensions ideal for high-density ball cargo decks.

MX 'Cargo' Series – Steel scraper cap protects against impact damage from misaligned loads. Multiple debris/drain channels rapidly eject contamination & fluid.

MW 'Washdown' Series – internal stainless steel liner cup provides a cost efficient alternative to all stainless steel construction. Effective corrosion resistance & fluid draining in washdown applications. Also available in all stainless steel.

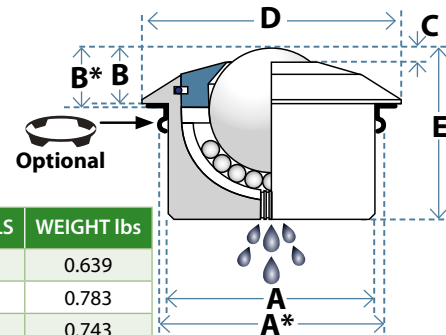
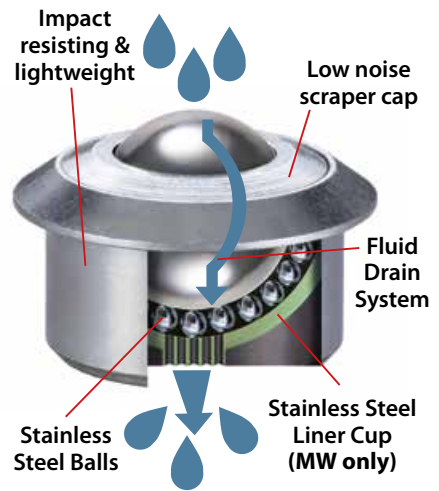

PART	LOAD lbs	BALL Ø	WITHOUT CLIP		WITH K-TYPE CLIP			C	D	E	DRAIN CHANNELS	WEIGHT lbs
			A	B	Clip #	A*	B*					
MV30	772	1 3/16"	1.772	0.543	K30	1.811 - 1.831	0.555	0.217	1.969	1.370	4 slots	0.639
MX30	772	1 3/16"	1.772	0.543	K30	1.811 - 1.831	0.555	0.217	2.165	1.449	7 holes	0.783
MW30	485	1 3/16"	1.772	0.543	K30	1.811 - 1.831	0.555	0.217	2.165	1.449	5 holes	0.743
MX45	1323	1 3/4"	2.441	0.748	K45	2.480 - 2.500	0.760	0.354	2.953	2.106	7 holes	2.227
MW45	992	1 3/4"	2.441	0.748	K45	2.480 - 2.500	0.760	0.354	2.953	2.106	1 hole	2.116

Using fixing clips changes values A & B to A & B*.



K & C Type Clips

✓ Compensate for irregularities in bore & diameter

✓ Ideal where only single-sided access of mounting surface is reachable

- 1 Fit clip to mounting bore
- 2 Push ball transfer through clip
- 3 Peripheral tags expand & grip the ball unit

MEDIUM DUTY	LIGHT DUTY	CLIP	A	BORE Ø MIN/MAX	INCREASED FITTED HEIGHT
M14 - M15 - MG15	L15 - LP15	K15	0.945	0.984-1.004	0.012 +
		C15	0.945	0.976-0.984	0.012 +
M22 - MG22	L22 - LP22	K22	1.417	1.457-1.476	0.012 +
		C22	1.417	1.457-1.465	0.012 +
M30 - MG30 - MV30 MX30 - MW30	L30 - LP30	K30	1.772	1.811-1.831	0.012 +
		C30	1.772	1.823-1.839	0.012 +
M45 - MG45 - MX45 - MW45	L45 - LP45	K45	2.441	2.480-2.500	0.012 +

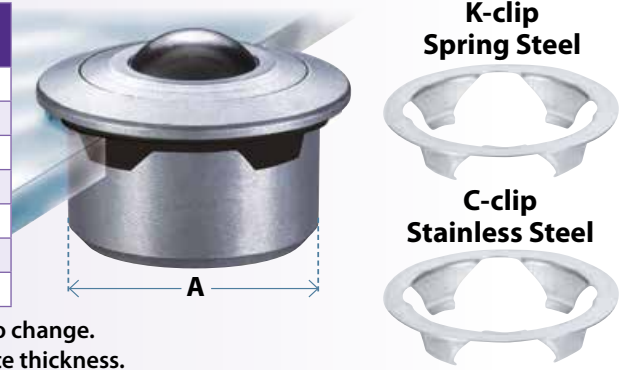

Other clips available.

Fixing clips cause fitted height & bore Ø values to change.
Effective retention requires 0.125" minimum plate thickness.

Tolerance Rings

✓ Ideal where only single-sided access of mounting surface is reachable

✓ Compensate for irregularities in bore & diameter

Bore Ø specifications change when using Tolerance Rings. Contact us if in doubt.

HEAVY DUTY	MEDIUM DUTY	LIGHT DUTY	PART	A	BORE Ø MIN/MAX	B
	MG8		TR18	0.709	0.760 - 0.770	0.236
9000 - 9001*	MG10		TR20	0.787	0.858 - 0.868	0.472
9010*	M12 - MG12			0.866	0.937 - 0.947	0.472
9300* - 9310*	M14 - M15 - MG15	L15 - LP15	TR24	0.945	1.010 - 1.020	0.591
9500* - 9501* - 9601*			TR25	0.984	1.071 - 1.081	0.315
	M22 - MG22	L22 - LP22	TR36	1.417	1.488 - 1.496	0.472
9020* - 9021* - 9022* - 9320* - 9321*	M30 - MG30 - MV30 MX30 - MW30	L30 - LP30	TR45	1.772	1.843 - 1.850	0.591
9030 - 9031* - 9330 - 9520*			TR50	1.969	2.043 - 2.051	0.591
9040 - 9041* - 9042* - 9341			TR60	2.362	2.445 - 2.453	0.787
9530*	M45 - MG45 - MX45 - MW45	L45 - LP45		2.441	2.531 - 2.539	0.787
9540* - 9640*				2.756	2.836 - 2.841	0.787
9050 - 9350 - 9051*	M60 - MG60		TR100	3.937	4.085 - 4.096	0.866

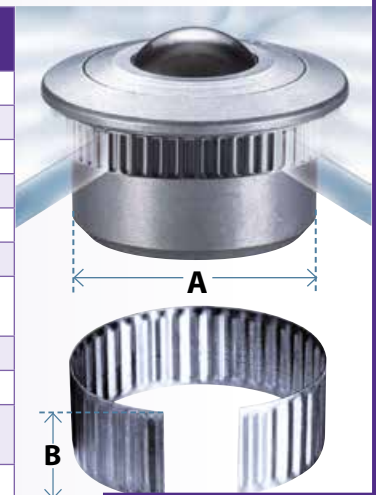

98 Series - see page 5.

* Ø Min/Max tolerance varies - Contact Us.

Nyloc Nut & Washer + 'T' wood insert kits

Use with Heavy Duty 91 Series, Medium Duty MSP Series & Omnicaster Ball Casters.

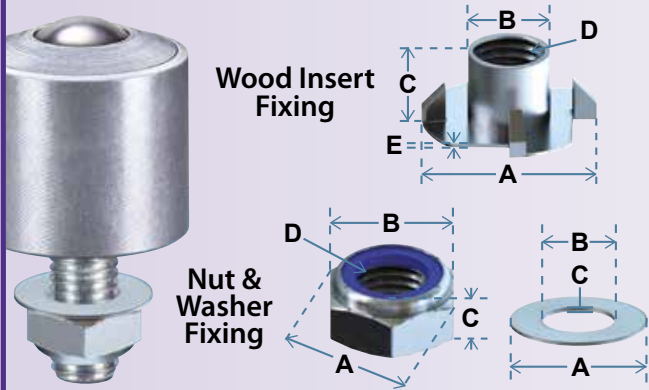

Other thread types & sizes available on request.

Model	9100 - 9101		OC35 - OC50 OC55 - OC55B		9120 - 9123 9130 - 9133					
	MSP10 - MSP12 MSP15 - MSP19				MSP22 - MSP30					
	OC30 - OC30F				OC100 - OC100B					
Fixing	T8	N8	T10	N10	T12	N12				
A	0.875	0.567	0.630	0.984	0.744	0.787	1.063	0.831	0.945	
B	0.358	0.512	0.315	0.441	0.669	0.394	0.551	0.748	0.472	
C	0.433	0.315	0.063	0.516	0.394	0.079	0.551	0.472	0.098	
D	M8 x 1.25		M10 x 1.5		M10 x 1.5		M12 x 1.75		M12 x 1.75	
E	0.051		0.055		0.071					



Low Friction
1: 0,03



Speed
3 ft/sec



Temperature
-4 to 160 °F



Orientation
Horizontal/
ball up



Economy
Value



LD - SATURN TYPE

Pressed steel 'Saturn' units are easily secured or riveted using integral fixing holes & are ideal for many light duty, low profile conveying applications. Models feature single drain hole & felt seal except LD16. LD32-SS & LD32/3-SS omit felt seal, other variants feature 7 rapid drain holes.

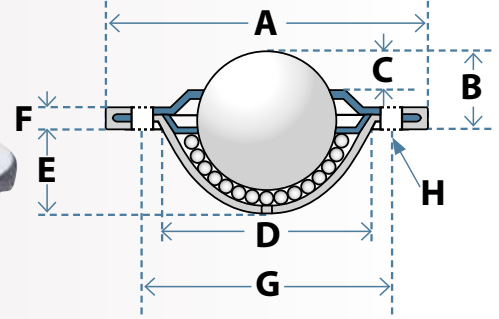

MAXIMUM LOAD Capacity & NETT WEIGHT lbs

PART	STANDARD		A		D		SS		Ball Ø	A	B	C	D	E	F	G	H
	LOAD	WEIGHT	LOAD	WEIGHT	LOAD	WEIGHT	LOAD	WEIGHT									
LD16	33	0.098	22	0.098	22	0.066	NA	NA	5/8"	1.614	0.422	0.197	0.945	0.335	0.125	1.181	2 x 0.134
LD19	55	0.197	55	0.195	44	0.139	55	0.190	3/4"	2.406	0.394	0.125	1.145	0.472	0.125	1.750	2 x 0.201
LD19/3	55	0.195	55	0.193	44	0.136	55	0.190	3/4"	2.406	0.394	0.125	1.145	0.472	0.125	1.750	3 x 0.201
LD23	265	0.211	198	0.212	50	0.130	NA	NA	7/8"	1.772	0.391	0.244	1.297	0.703	0.141	1.535	3 x 0.138
LD25	120	0.374	120	0.366	55	0.242	120	0.379	1"	2.875	0.563	0.250	1.469	0.625	0.141	2.188	2 x 0.201
LD25/3	120	0.371	120	0.367	55	0.243	120	0.377	1"	2.875	0.563	0.250	1.469	0.625	0.141	2.188	3 x 0.201
LD26	132	0.276	88	0.277	50	0.154	NA	NA	1"	2.203	0.578	0.307	1.417	0.609	0.130	1.772	2 x 0.157
LD32	275	0.593	275	0.593	NA	NA	275	0.564	1 1/4"	2.906	0.641	0.313	1.796	0.781	0.165	2.313	2 x 0.201
LD32/3	275	0.592	275	0.588	NA	NA	275	0.561	1 1/4"	2.906	0.641	0.313	1.796	0.781	0.165	2.313	3 x 0.201

LD32-SS & LD32/3-SS units feature 7 large fluid drain holes & omit felt seal.

LF - FLANGE MOUNTED 2 & 4 HOLE

High profile, surface mounted units with fixing flange. Pressed steel construction with either 2 or 4 fixing points. LF26 units incorporate 2 slots rather than holes to accommodate varying fixing centers (2.203" - 2.375"). LF units feature debris drain hole. Models LF25 & LF38 omit felt seal.

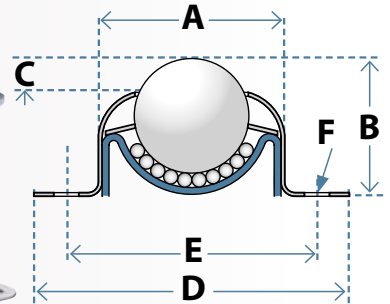

MAXIMUM LOAD Capacity & NETT WEIGHT lbs

PART	STANDARD		A		D		SS		Ball Ø	A	B	C	D	E	F
	LOAD	WEIGHT	LOAD	WEIGHT	LOAD	WEIGHT	LOAD	WEIGHT							
LF25	125	0.311	NA	NA	NA	NA	NA	NA	1"	1.656	1.188	0.312	2.750 x 2.0	2.189	2 x 0.221 Ø
LF26	125	0.342	125	0.340	60	0.214	125	0.333	1"	1.781	1.234	0.25	2.718 x 2.0	2.203 - 2.375	2 x 0.217 x 0.303 slot
LF38	250	1.146	NA	NA	NA	NA	NA	NA	1 1/2"	2.625	1.813	0.375	3.0 x 3.0	2.468 x 2.468	4 x 0.281 Ø

LM - CASED SPRING LOADED

Load equalising spring loaded unit with integral moulded nylon seal. Internal coil spring deflects for biased loads or to compensate for surface irregularities. Carbon chrome balls & zinc plated pressings.

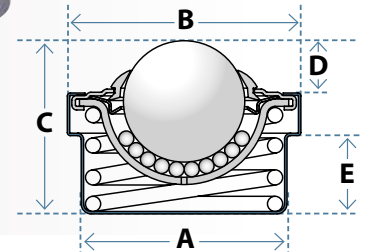

PART	SUPPORT LOAD lbs	DEFLECTION inch	LOAD AT MAX DEFLECTION	BALL Ø	A	B	C	D	E	NETT WEIGHT lbs
LM25	45	0.172	120	1"	1.713	1.938	1.406	0.406	0.625	0.384

L - PUSH FIT & CLIP FIXING RANGE

Push fit retention for rapid installation & replacement where only single-sided access of mounting surface is reachable. Compensate for irregularities in seating bore diameter using optional (spring steel) 'K-clips', or (stainless steel) 'C-clips'. When using optional clips dimensions 'A' & 'B' become 'A*' & 'B*'. K-clip seating bore values are shown below - see page 11 for all fixing clips & tolerance ring details.

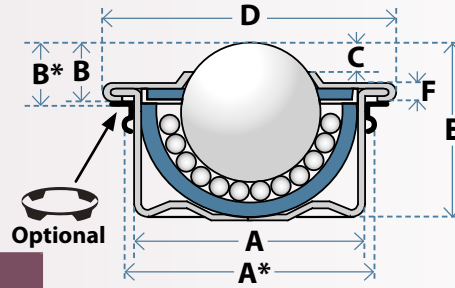

MAXIMUM LOAD Capacity & NETT WEIGHT lbs

PART	STANDARD		A		D		SS		Ball Ø	A & A*	B & B*	C	D	E	F
	LOAD	WEIGHT	LOAD	WEIGHT	LOAD	WEIGHT	LOAD	WEIGHT							
L15	135	0.089	135	0.087	22	0.058	85	0.086	5/8"	0.945	0.375	0.181	1.219	0.828	0.109
L15-K	135	0.089	135	0.087	22	0.058	85	0.086	5/8"	0.984 - 1.004	0.386	0.181	1.219	0.828	0.109
L22	350	0.282	350	0.276	44	0.194	200	0.276	7/8"	1.417	0.386	0.154	1.772	1.161	0.114
L22-K	350	0.282	350	0.276	44	0.194	200	0.276	7/8"	1.457 - 1.476	0.398	0.154	1.772	1.161	0.114
L30	600	0.557	600	0.548	55	0.339	450	0.597	1 3/16"	1.772	0.543	0.268	2.165	1.457	0.141
L30-K	600	0.557	600	0.548	55	0.339	450	0.597	1 3/16"	1.812 - 1.831	0.555	0.268	2.165	1.457	0.141
L45	1200	1.587	1200	1.565	NA	NA	575	1.565	1 3/4"	2.441	0.748	0.354	2.953	2.106	0.156
L45-K	1200	1.587	1200	1.565	NA	NA	575	1.565	1 3/4"	2.480 - 2.50	0.760	0.354	2.953	2.106	0.156

All variants with 7/8" & 1 3/16" main balls feature a felt seal.
Values A & B change to A* & B* when using K-clips.

LP - ALL PLASTIC & CLIP FIXING RANGE

Machined Acetal (POM) plastic housing fitted with either Acetal (POM) balls or AISI 316 stainless steel balls (add suffix 'A').

- Resists salt water & chemical attack
- Non conductive & non magnetic
- Suited to antimicrobial applications

Optional fixing clips & rings - see page 11.
Spring steel 'K-clips' & 'C-clips'/tolerance rings in stainless steel.

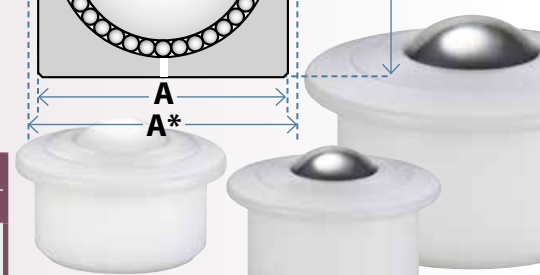
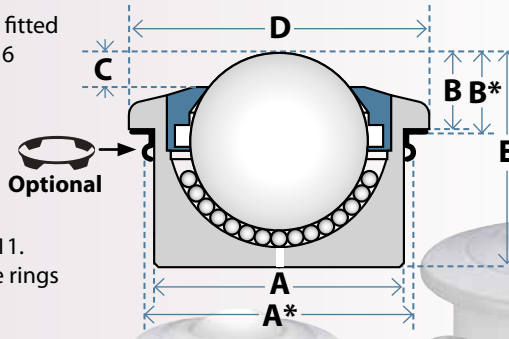

MAXIMUM LOAD Capacity & NETT WEIGHT lbs

PART	STANDARD		A		Ball Ø	A & A*	B & B*	C	D	E
	LOAD	WEIGHT	LOAD	WEIGHT						
LP15	15	0.021	15	0.059	5/8"	0.945	0.315	0.188	1.181	0.787
LP15-K	15	0.021	15	0.059	5/8"	0.984 - 1.004	0.326	0.188	1.181	0.787
LP22	22	0.078	22	0.110	7/8"	1.417	0.386	0.177	1.772	1.203
LP22-K	22	0.078	22	0.115	7/8"	1.457 - 1.476	0.398	0.177	1.772	1.203
LP30	33	0.144	33	0.384	1 3/16"	1.772	0.543	0.228	2.165	1.457
LP30-K	33	0.144	33	0.384	1 3/16"	1.812 - 1.831	0.555	0.228	2.165	1.457
LP45	45	0.402	45	1.102	1 3/4"	2.441	0.748	0.335	2.953	2.106
LP45-K	45	0.402	45	1.113	1 3/4"	2.480 - 2.50	0.760	0.335	2.953	2.106

Values 'A' & 'B' become A* & B* when using K-type clips.
All LP series omit felt seal.

FIXING CLIPS 'K-clips' spring steel 'C-clips' stainless steel.

- Compensate for irregularities in bore & diameter
- Ideal when only single sided access of mounting surface is reachable

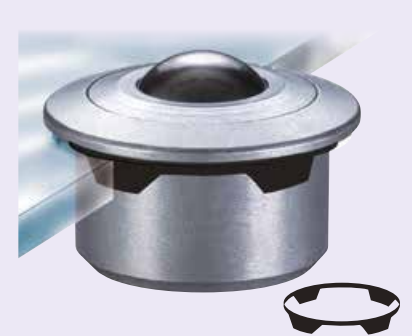

Adding suffix 'K' or 'C' to ball unit part number will specify supply of the optional clip (eg 'L22K' or 'L22C'). When using clips, fit the clip to the bore & then push the ball unit through the clip. Peripheral tags expand & securely retain the ball unit.

Dimensions A & B change to A* & B* when using clips. Tolerance ring & full clip options shown on page 11.



Temperature
-22 to 195 °F



- Fast directional change - easier steering than traditional casters
- Glide smoothly over carpet, wood & marble floors
- Multiple drain channels expel debris & fluids
- Effortlessly convey delicate materials with minimal damage

Brake Option



Speed
3 ft/sec



Rapid Drain Options



Delicate Contact



Optional Fixing Kits

Wood Insert Fixing

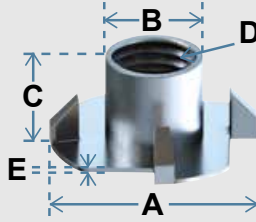

Nut & Washer Fixing

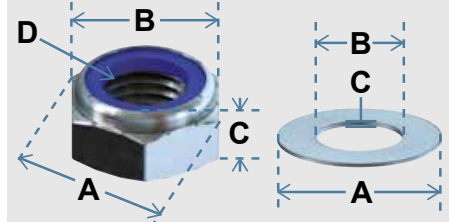

Model	OC 30 \ OC 30F			OC35 \ OC50 OC55 \ OC55B			OC100 \ OC100B		
Fixing	T8	N8		T10	N10		T12	N12	
A	0.875	1.567	0.630	1.0	0.744	0.787	1.063	0.831	0.945
B	0.359	0.512	0.316	0.441	0.669	0.394	0.551	0.748	0.472
C	0.438	0.316	0.063	0.516	0.394	0.078	0.551	0.472	0.098
D	M8 x 1.25	M8 x 1.25		M10 x 1.5	M10 x 1.5		M12 x 1.75		M12 x 1.75
E	0.051			0.056			0.078		

Imperial dimensions subject to general tolerance of +/- 0.012" inch

OC30 & OC30F



Push Fit

PART	OC 30 & OC 30F~
MAX LOAD lbs	66
BALL Ø	1 3/16"
A	2.512
B / B~	2.106 / 2.047 ~
C / C~	0.354 / 0.295 ~
D / D* ø	0.984 / 1.260 *
E / E*	0.512 / 0.709 *

~'Fixed'/non rolling caster*
Values using 'Quick Fit' adaptors

Q12

Countersink 0.394"

Q13

M8

Q14

M10

Q15

UNC 3/8"

Q16

Gripneck 10mm

Q17

Gripneck 11mm

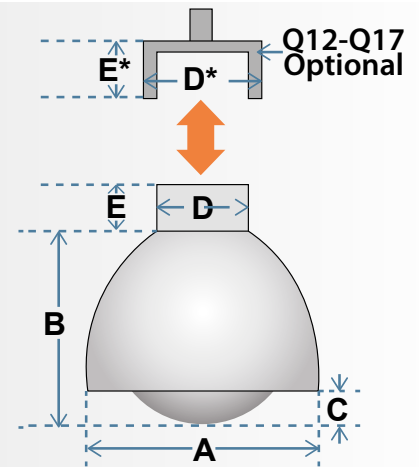

Quick Fit Adaptors

OC35



Debris Exit

PART	OC 35
MAX LOAD lbs	66
BALL Ø	1 3/16"
A	2.362
B	2.362
C	0.378
D ø	1.732
E	0.984
F	M10 x 1.5

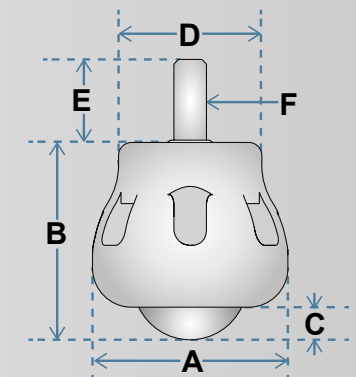

OC50

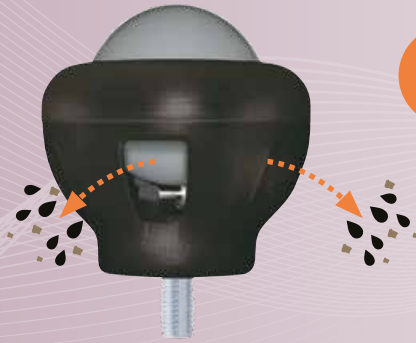

PART	OC 50
MAX LOAD lbs	130
BALL Ø	2"
A	2.953
B	3.031
C	0.701
D	1.732
E	0.984
F	M10 x 1.5

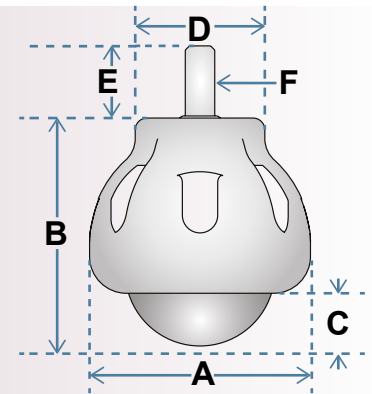

OC55 & OC55B



PART	OC 55 & OC55B
MAX LOAD lbs	130
BALL Ø	2"
A	2.992
B	3.307
C	0.531
D ø	1.623
E	0.591
F	M10 x 1.5
G	1.358" (OC55) 1.024" (OC55B)

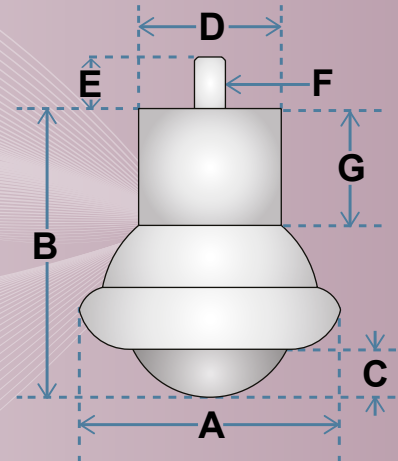

OC100 & OC100B



PART	OC 100 & OC 100B
MAX LOAD lbs	175
BALL Ø	4"
A	5.630
B	5.965
C	1.142
D ø	2.283
E	0.984
F	M12 x 1.75
G	1.812" (OC100) 1.339" (OC100B)

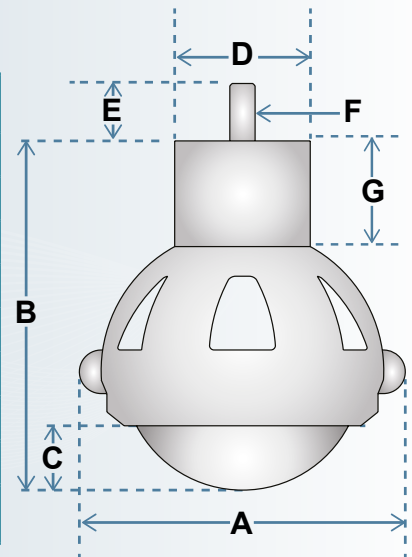

Imperial dimensions subject to general tolerance of +/- 0.012" inch

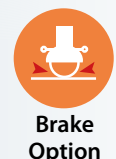



OMNIFLOAT & OMNIWHEEL

omnifloat®

Omnifloat casters allow smooth conveying & directional change with minimal damage to delicate surfaces. Specified throughout the glass handling industry for conveying glass through wet, corrosive, dusty & high temperature processes.

Omnifloats are typically supplied with a 50% mix of 'left hand' & 'right hand' swivel trail. We recommend fitting the casters in a regular, alternate pattern to minimise bias & provide a neutral conveying plane.

Replacement balls available as spares. Alternative materials can be retro-fitted for extended durability & service.

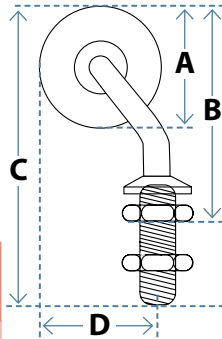

PART	MAX LOAD lbs	A BALL Ø	B MIN-MAX	C	D	THREAD
OF 35-55	40	1 3/8"	2.125-2.992	3.622	1.083	M14 x 1.5
OF 35-75	40	1 3/8"	2.125-2.795	3.425	1.476	M14 x 1.5
OF 50-100	50	2"	2.717-3.583	4.213	1.969	M14 x 1.5

Specify your materials:

R = **Rubber Ball add suffix 'R'**
Better Grip (Black)
70 Shore 'A' -4°F to +175°F

P = **Polyurethane Ball add suffix 'P'**
Wear resistant (Caramel)
92 Shore 'A' -4°F to +175°F

HT = **High Temperature add suffix 'HT'**
Heat resistant (Red)
80 Shore 'A' -4°F to +300°F

Standard arm is zinc plated steel (AISI 1113)

SS = **Corrosion/Chemical attack?**
Specify Stainless Steel Arm AISI 304

To Order:

1. Select model: OF35-55 / OF35-75 / OF50-100
2. Specify Ball material: 'R'= Rubber, 'P'= Polyurethane & 'HT'= High Temperature (i.e. OF35-75HT)
3. Stainless Steel Arm required? Add suffix 'SS' (otherwise zinc plated steel arm)

omniwheel®

Omniwheels feature 3 peripheral polyamide rollers which rotate on stainless steel axles. Ideal for assembly lines, machine feed & packing areas.

Produced with either:

- **PLAIN BORE** for gravity fed conveyor systems
- **HEX-DRIVE CENTER** (suffix '-H') for hexagon driven conveyor systems.

Lock Omniwheels together in series for 360 degree support across narrow or irregular shaped items. We can supply spacer tubes (pre-cut to the required length) to reduce density for items with larger surface area.



Twin

Spaced Twin

Series

PART	MAX LOAD lbs	WHEEL Ø	A	B	C	D	E
OW48	18	1.891	0.844	0.118	0.118	1.578	Ø 0.323"
OW48-H	18	1.891	0.844	0.118	0.118	1.578	0.139" HEX DRIVE
OW80	55	3.150	1.344	0.157	0.157	2.562	Ø 0.480"
OW80-H	55	3.150	1.344	0.157	0.157	2.562	0.441" HEX DRIVE

Easily combine with existing gravity (plain) or driven (Hex) systems

Ideal in dirty, wet & dusty conditions

Greater support for irregular or deformable items

Use singularly with spacers or lock together in series for greater contact

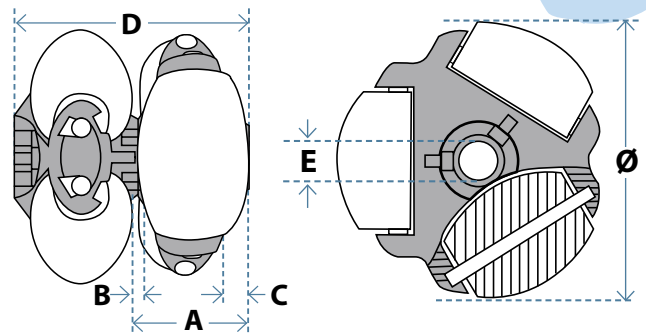

Omnitrack Flexible Conveyors - versatile & mobile conveyor modules. Compact conveyors extend up to 3.6 times their retracted length & sturdy casters are then locked once positioned. All models are height adjustable & assembled with either Skatewheels (for flat based items & tighter turns) or Conveyor Rollers (for increased support of irregular/deformable items). Rollers & wheels are produced from low-inertia, high-impact PVC.

- 55 lbs/foot load rating
- Adjustable working height (25.5" - 43")
- Maximum axle pitch 4.921" (extended)
- 15.750" or 23.625" standard conveyor width
- Other models & materials available.

FLEXIBLE CONVEYORS WITH SKATEWHEELS

– for flat-based items & for tighter turns



15.750" WIDTH	23.625" WIDTH	EXTENDED LENGTH	RETRACTED LENGTH
S400/2000	S600/2000	78.7	24.8
S400/3500	S600/3500	137.8	40.2
S400/5000	S600/5000	196.9	55.5
S400/6500	S600/6500	255.9	70.9
S400/8000	S600/8000	315.0	86.2
S400/9500	S600/9500	374.0	101.6

Dimensions in inches



FLEXIBLE CONVEYORS WITH ROLLERS

– for increased support of irregular/deformable items

15.750" WIDTH	23.625" WIDTH	EXTENDED LENGTH	RETRACTED LENGTH
R400/2000	R600/2000	78.7	37.0
R400/3500	R600/3500	137.8	61.4
R400/5000	R600/5000	196.9	85.8
R400/6500	R600/6500	255.9	110.2
R400/8000	R600/8000	315.0	134.6
R400/9500	R600/9500	374.0	159.1

Dimensions in inches



Optional Connecting Hooks link multiple conveyors together. (CH1)

PART	OPTIONAL PARTS
CH1	Connecting Hooks (1 Pair)
ES400	End Stop (15.750" width)
ES600	End Stop (23.625" width)

Optional End Stops (ES400/ES600) or Ball Platforms & Tables (page 19).





Omnitrack Ball Transfer Rails - construct a custom & flexible conveying plane by configuring ball transfer rails to your application. Ideal in live storage applications, the rails can be installed individually using optional fixing brackets or bolted together either with or without optional spacer tubes to form a ball transfer platform.

15.750" & 23.625" standard lengths for rapid integration within existing conveyor roller installations. Ball transfer units available with alternative material upgrade options.



BALL Ø	RAIL LENGTH # OF BALL UNITS @ SPACING "				MAX LOAD lbs												A RAIL WIDTH	B FITTED HEIGHT	C RAIL HEIGHT
	15.750" LENGTH		23.625" LENGTH		STANDARD MATERIALS			A			D			SS					
					Carbon steel bearings, zinc pressings			Stainless steel balls, zinc plated pressings			Nylon load ball, zinc plated pressings			Stainless steel bearings & pressings					
	Unit	400	600	Unit	400	600	Unit	400	600	Unit	400	600	Unit	400	600				
0.625	R15-400	10 @ 1.575	R15-600	15 @ 1.575	130	1300	1950	130	1300	1950	22	220	330	90	900	1350	1.575	1.358	0.984
0.875	R22-400	8 @ 1.969	R22-600	12 @ 1.969	350	2800	4200	350	2800	4200	44	352	528	200	1600	2400	1.969	1.37	0.984
1.188	R30-400	7 @ 2.264	R30-600	10 @ 2.362	620	4340	6200	620	4340	6200	55	385	550	450	3150	4500	2.362	1.528	0.984

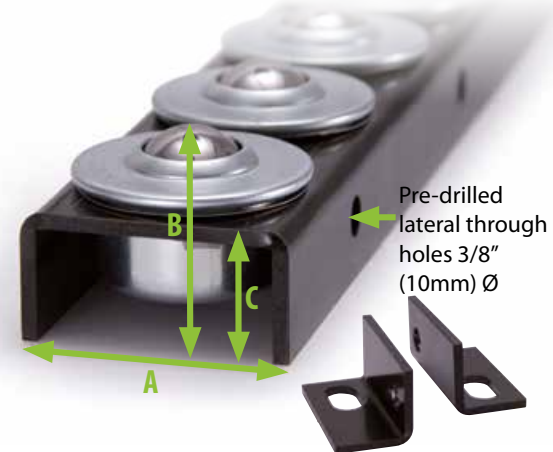
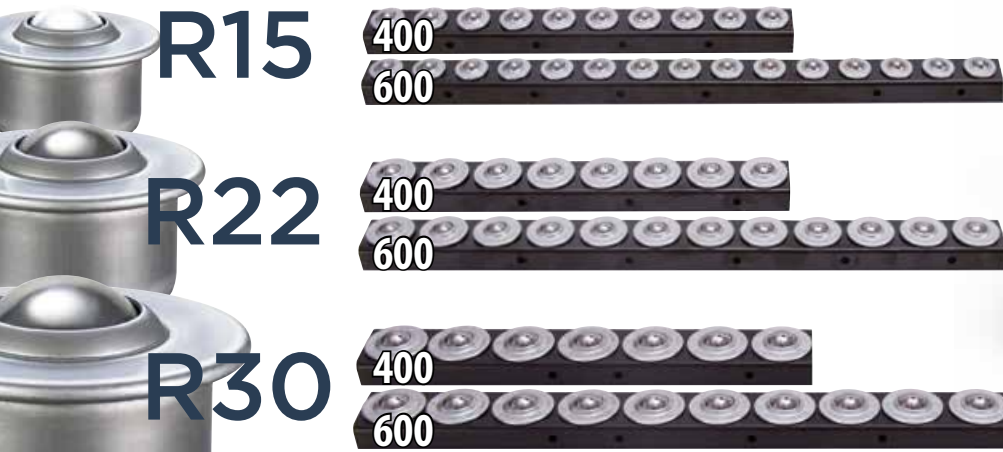

BALL TABLES & CONVEYING PLATFORMS

We'll design & build your custom solution.
Just send us your application criteria:

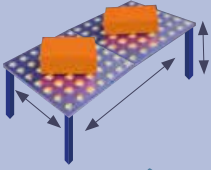

Table/platform dimensions.
Sides & end stops?



Conveyed item(s) - maximum/minimum dimensions & weights



Conveyed item(s) - material & finish, deformability & flatness.

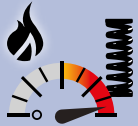

Special operations – shock loads, speed, assembly procedures.



Operating environment - outdoors, refrigerated conditions, hygienic areas, washdown areas.

Also consider:
Flexible Conveyors



Ball Rails



CONTACT US NOW

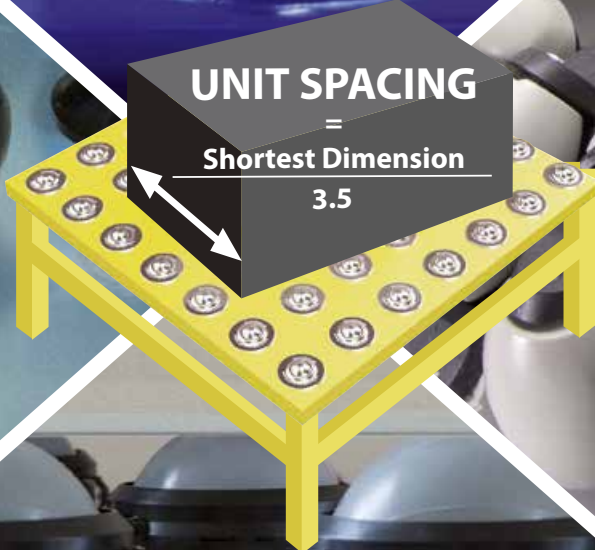
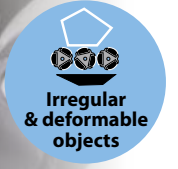
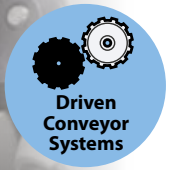
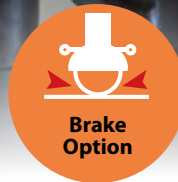
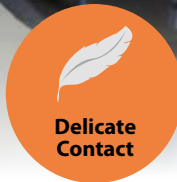
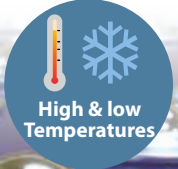

Ball Skate BB30/4



Lightweight & durable construction



2240 lbs



Load per skate

Parking



brake standard

Corrosion



resisting S/S Balls

Accepts most standard legs

Circular Leg Recess
0.812" Ø - 3.156" Ø

Optional Load Plate

Square Leg Recess
0.812" - 4" square

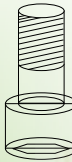

- 1/2" Ø through counter bore for:
- Optional Load Plate
- Socket head screw for permanent attachment.



Ground Clearance 0.547"
Ball Projection 0.219"

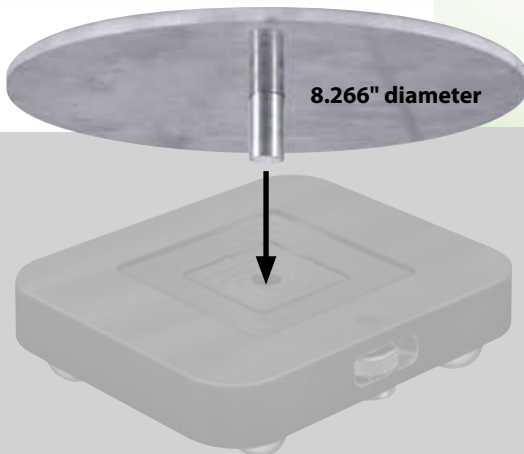

Load Plate - Part # BL2

Ideal where flat or wide surfaces require increased support. Easy push fit & removal utilising central hole in skate.

Pry Bar - Part # BP2

Use to lift or lever items & fit/remove ball skates. Heavy duty 2-piece design for ease of transport.



Shelving Tie Brackets - Part # BS2

Ball skates are ideal to move laden connected shelving aisles. Use universal tie brackets to secure upper areas of connected gondola shelving.



DESIGN CONSIDERATIONS

Evaluate these aspects when choosing your solution:

<h4>Orientation</h4> <p>Which position does your application require the units to be mounted or function? Load ball 'up', 'down' or other? Heavy duty range units operate at maximum load in all orientations.</p>	<h4>Track & Contact</h4> <p>What is the condition, hardness & surface finish of the material the units will be conveying or bearing against? Uneven, deformable & delicate surfaces need special consideration.</p>	<h4>Load</h4> <p>Dynamic & static load ratings are identical. Where loads are unevenly distributed or high impact/shock conditions exist, spring loaded units are ideal.</p>
<h4>Speed</h4> <p>Maximum conveying speeds are limited; frequency & duration may also require consideration. Dynamic & static speed ratings are identical.</p>	<h4>Friction & Precision</h4> <p>Lowest coefficient of friction & highest levels of precision movement are provided by the heavy duty ball units (pages 4 - 7). Some applications will allow a design concession to be made</p>	<h4>Stability</h4> <p>Consider the stability of the conveyed item. Ensure sufficient points of contact (pitch) to consistently support the mass. Provision for control & braking of the mass should not be overlooked.</p>
<h4>Environment</h4> <p>Consider material upgrade options to better resist adverse environmental operating conditions. Dirty or dusty conditions? Wet & contaminated areas? Chemical attack/contamination? Magnetic permeability & radioactive fields?</p>	<h4>Lubrication & Service</h4> <p>Omnitrack products are lubricated for life. Heavy duty & Omnifloat ranges offer additional user-service kits (see page 21) to further extend service life.</p>	<h4>Temperature</h4> <p>Ambient temperature & maximum/minimum temperature ranges must be evaluated. Stainless steel components resist higher & lower temperatures better than standard materials - consult temperature chart on page 23.</p>

CONTACT US NOW

Drawings are available for all of our parts online

	Max Load	Friction % of Load	Speed feet/sec	Shock loads		Arduous conditions		Orientation	Instant change
Heavy Duty	120-18000	0.5	6.5	✓✓✓✓✓ 94-97 Series	✓✓✓✓✓ 90-93 & 98 Series	✓✓✓✓✓	Z' & 'SS' options		✓✓✓
Medium Duty	45-7700	2	4.5	✓✓✓✓✓ MM - MN Series	✓✓✓✓ MX Series	✓✓✓✓	MW, MV30 & 'SS' option		✓✓✓
Light Duty	15-1200	3	3	✓✓✓	✓ LM series	✓✓	'SS' options		✓✓✓
Omnicaster	65-175	3	3	✓		✓✓✓			✓✓
Omnwheel	18 & 55	5	3	✓		✓✓✓✓✓			✓
Omnifloat	40 & 50	6	3	✓✓		✓✓✓✓✓			✓
Flexible Conveyors	55lbs/foot	4	6.5	✓✓		✓✓✓✓✓			✓✓
Rails & Tables	220-660	3	3.5	✓		✓✓			✓
Skates	2240	3	4.5	✓✓		✓✓✓			✓

TECHNICAL REFERENCE

HEAVY DUTY BALL UNITS

"Anti-oxide" electrophoretic black finish
>330 hours ISO salt resistance.
Stainless steel units - natural finish

Felt Seal
as standard
(Ball Ø > 1/2")

Lubricated for life -
Mobil Vactra 1 Oil

18000 lbs
LOAD RATINGS UNAFFECTED AT ANY ORIENTATION

Standard & **A**
1 x drain channel

Z
2 x drain channels

DEBRIS & DRAIN CHANNELS
All units (main ball > 5/8")

Component materials & Corrosion resistance

SS	'All Stainless steel'	1	1	1	5	3	3	+ 1 = AISI 304 stainless steel 2 = AISI 302 stainless steel 3 = AISI 440 stainless steel 4 = AISI 1050 'Anti-oxide' finish 5 = AISI 1070 chrome steel 6 = AISI 52100 chrome steel -
Z	'Arduous Conditions'	4	4	1	5	3	3	
A	'Stainless steel balls, other materials as standard'	4	4	6	5	3	6	
	Standard Materials	4	4	6	5	6	6	

LOAD & STABILITY

6600 lbs

Ensure sufficient load capacity.

$\frac{\text{Load}}{3} = 3 \times 2200\text{lbs}$

Unit spacing = $\frac{\text{shortest dimension}}{3.5}$

Specify Spring Loaded units where shock loads or uneven track or load conditions exist.



Free technical advice

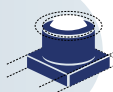

Custom design



In-house manufacturing

OPERATING TEMPERATURE

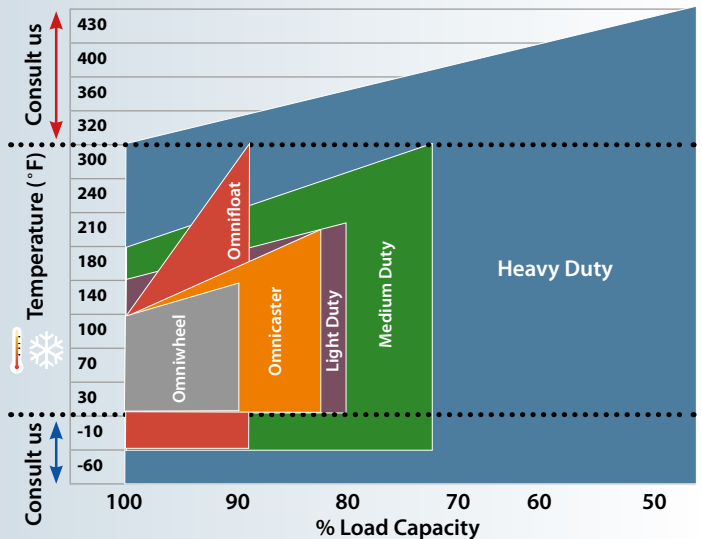

omnitrack®



omnicaster®



omnifloat®



omniwheel®



UNITED KINGDOM
01453 873345



FRANCE
01 8721 0069

CANADA
1 647 258 4756



DEUTSCHLAND
0800 813 3297

USA
1 914 600 5422



ITALIA
051 082 6927

MÉXICO
01800 681 9310



ESPAÑA
91 198 4543

BRASIL
11 434 96211



PORTUGAL
308 804 777

AUSTRALIA
1800 824 493



ROMANIA
0364 228 049

NEW ZEALAND
03 669 4787



РОССИЯ
8800 100 9654

SOUTH AFRICA
010 595 1272



NEDERLAND
020 703 8306

TÜRKİYE
0216 900 2808



COLOMBIA
(1) 3819434

INDIA
000 800 100 4384

**DAILY
WORLDWIDE
SHIPPING**



omnitrack®
omnidirectional movement

**SINCE
1909**



☎ 1 800 817 0423



info@omnitrack.com www.omnitrack.com
Omnitrack Ltd - Rodborough Court - Stroud - GL5 3LR - England