

omnitrack™

OMNI-DIRECTIONAL MOVEMENT SOLUTIONS



100 *Years*
of innovation

2011

"Bloodhound" 1000mph
Land Speed Record
(Product Sponsor)



1988

Euro Fighter production
project supplier

1970

Blue Steel nuclear warhead
handling equipment –
design & production

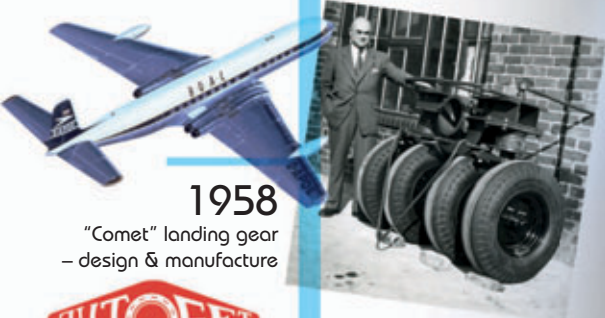

1958

"Comet" landing gear
– design & manufacture



AUTOSET
(PRODUCTION) LTD

1952

Patented Omnitrack Ball Unit
range – production launched



1928

Gravity convey rollers,
Skatewheels & live racking
systems launched



1923

TST "Townsend, Skinner
& Tingle" car produced



1930

Belt "Linisher" designed & launched

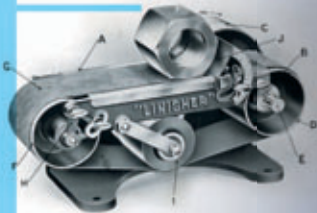

1918

"Autoglider" scooter range
produced & exported



1909

Inception as manufacturer of
Lathes, heavy duty Castors &
Cabinet Drawer Slides

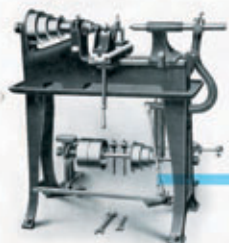

100

Years
of movement solutions

omnitrack™



- Low friction & heavy loads
- Instant directional change
- Smooth, precise conveying at high speed
- High resistance to shock & temperature
- Drain channels for debris & liquids
- Wide choice of material upgrades

omniball™



- Suitable for delicate surfaces
- Self-cleans in operation
- Large ball projection
- Water resistant parts suited to outdoor use

omnifloat™



- Ideal for glass & other sheet materials
- Extra hard-wearing & high heat ball upgrade options
- Stainless Steel arm for wet & corrosive conditions
- Replaceable parts (page 2)

omniwheel™



- Resists dirt, wet & dusty conditions
- Easy integration into existing gravity (plain) or driven (hex) systems
- Greater support for irregular or deformable items
- Use singularly with spacers or lock together

SUPPORT & BUY



Amcats Pvt. Ltd.

+91-22-61464444

sales@amcats.com

+91-22-25564987

www.omnitrack.in

- No minimum order
- Immediate dispatch (most items)
- Free technical advice
- 'Specials' no problem, in-house production



Material Options & Corrosion Resistance

High



Low

Material types

- 1 = AISI 304
- 2 = AISI 302
- 3 = AISI 440
- 4 = AISI 1015 - special "Anti-Oxide" finish *
- 5 = AISI 1015 - zinc & trivalent passivation finish
- 6 = AISI 1070
- 7 = AISI 52100

*"Anti-Oxide" finish with up to 330 hours ISO salt spray test resistance

Part	'SS'	'Z'	'A'	Standard
Topcap	1	4	5	5
Casing	1	4	5	5
Retainer	1	1	7	7
Circlip	2	6	6	6
Balls	3	3	3	7
Table	3	3	7	7

SERVICE KITS

Available for High Capacity units with a main ball Ø >12.7mm. Spring loaded units require tooling for safe disassembly – factory refurbishment only.

To order, quote part number followed by kit required (eg. '9341Z-S2'). Contact us for service instructions or if in doubt.

Factory refurbishment service available.

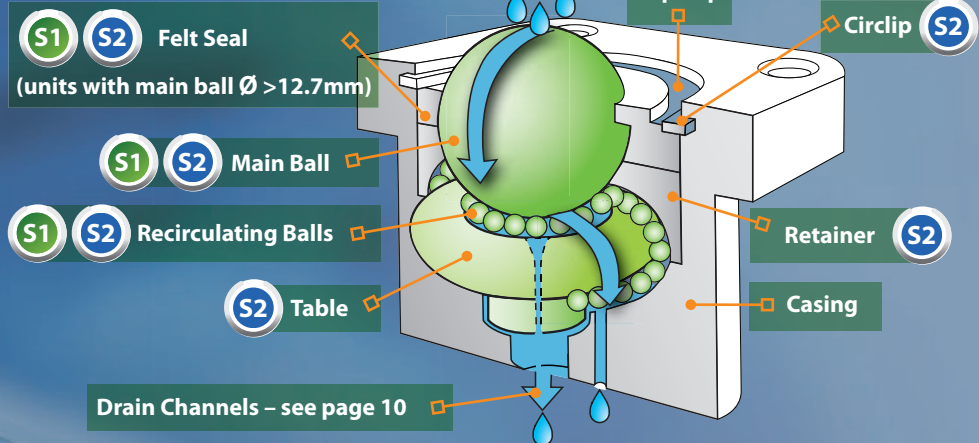

SERVICE KITS

OMNIFLOAT

Replacement balls available as spares. Alternative materials can be retro-fitted for extended durability & service.

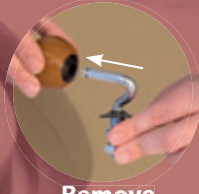

Remove

Snap fitting

Ball Ø mm

35

50

R = Rubber Ball
Better Grip (Black)
70 Shore 'A' -20°C to +80°C

S35R

S50R

P = Polyurethane Ball
Wear resistant (Caramel)
92 Shore 'A' -20°C to +80°C

S35P

S50P

HT = High Temperature Ball
Heat resistant (Red)
80 Shore 'A' -20°C to +150°C

S35HT

S50HT





HIGH CAPACITY RANGE - Maximum Precision

Low Friction



1:0,005

Speed



2 m/sec

Temperature



-30 to 160 °C

Orientation



ANY

High Shock



Resistance

Drain / Debris



Channels ▼

User



Serviceable ▼

▼ = Not applicable on units with Ball Ø 12.7mm

High Capacity "double recirculation" range offers maximum precision & smoothest performance. Machined from solid steel bar this innovative design provides the highest load capacity & longest service life available. User-serviceable with factory spares backup.

Standard Materials - high grade AISI 52100 chrome steel Balls & zinc plated carbon steel housing		Corrosion Resistance		Contaminated Environment		Temperature		Radiation Resistance	Delicate Surfaces
Solve specific application requirements by upgrading materials - select option by adding suffix.		Low	High	Low	High	Low	High		
A	Stainless Steel Balls (AISI 440) but other materials as Standard	✓	✓	✓	✓	✓	✓	✓	
Z	'Arduous Conditions' Stainless Steel (AISI440) = internal parts & Balls. "Anti-Oxide" finish to outer housing – see page 2	✓✓	✓✓	✓✓	✓	✓✓	✓	✓	
SS	All parts Stainless Steel – outer housing = AISI 304. Internal parts & Balls AISI 440	✓✓✓	✓✓✓	✓✓✓	✓✓✓	✓✓✓	✓✓✓	✓✓✓	
PB	Phenolic Resin main ball option available with 'Standard', 'Z' ('Arduous Conditions') & 'SS' (all Stainless Steel) material options – see Technical Reference on page 10 for load ratings								✓✓✓

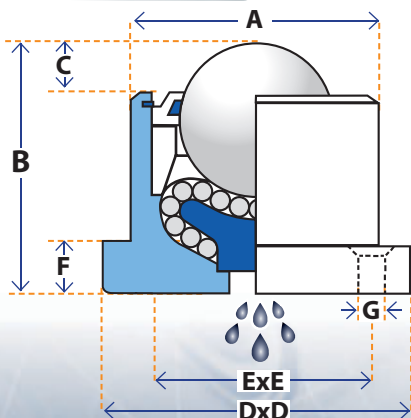
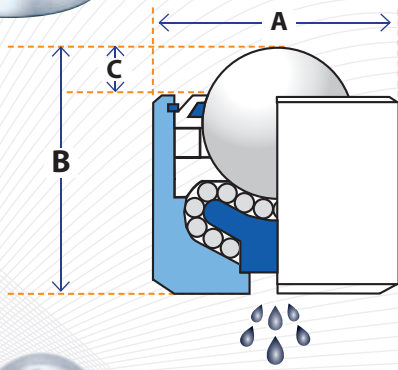

90 Series - PLAIN FIT

Part No	Load (kg)	Ball Ø	A	B	C
9000	46	12.7	20	20	3.8 ◆
9001	46	12.7	20.6	19.1 ✱	3.8 ◆
9010	46	12.7	22.2	22.2	3.8 ◆
9020	225	25.4	44	41.3	5.6
9021	225	25.4	44.5	41.3	5.6
9022	225	25.4	44.5	41.3	7.1
9030	375	25.4	50	44.5	6.4
9031	375	25.4	50.8	44.5	6.4
9040	1100	38.1	60	61.5	12.7
9041	1100	38.1	60.3	61.5	12.7
9042	1100	38.1	60.3	60.3	12.7
9050	2200	50.8	100	95	14.3
9051	2200	50.8	101.6	98.4	14.3
9060	4550	76.2	160	145	21

✱ 9001 has spigot 3.2mm x 8mm dia. ◆ further 1.5mm @ 16.2mm outside Ø

92 Series - FLANGE MOUNTED

Part No	Load (kg)	Ball Ø	A	B	C	D x D	E x E	F	G Ø
9200	46	12.7	23.8	22.2	3.8 ~	44.5 Ø ◆	34.9	3.2	2 x 3.6
9210	46	12.7	23.8	22.2	3.8 ~	47.7 x 32 ✱	34.9	2	2 x 4 ▼
9220	225	25.4	44	41.3	5.6	57.2	44.5	4.8	4 x 6.1
9221	225	25.4	44.5	41.3	7.1	57.2	44.5	4.8	4 x 6.1
9230	375	25.4	50	44.5	6.4	76.2	57.9	6.4	4 x 8.1
9240	1100	38.1	60	61.5	12.7	76.2	57.9	12.7	4 x 8.1
9241	1100	38.1	60.3	60.3	12.7	76.2	57.9	12.7	4 x 8.1
9250	2200	50.8	100	98.4	14.3	127	101.6	9.5	4 x 11.1 ▼
9260	4550	76.2	160	145	21	175	145	15	4 x 12.1

◆ 9200 - Circular flange ✱ 9210 - Elliptical flange

~ further 1.5mm @ 16.2mm outside Ø ▼ Not countersunk



91 Series - *THREADED STUD*

Part No	Load (kg)	Ball Ø mm	A	B	C	D	E	F
9100	46	12.7	20	19.1	3.8*	16.1		M8 x 1.25
9101	46	12.7	20.6	19.1	3.8*	28.7		M8 x 1.25
9102	46	12.7	20.6	19.1	3.8*	28.7		5/16" UNF
9112	46	12.7	22.2	22.2	3.8*	25.4		5/16" UNF
9120	225	25.4	44	48.3	5.6	25		M12 x 1.75
9123	225	25.4	44	47.3	5.6	25	6	M12 x 1.75
9124	225	25.4	44.5	47.3	7.1	25.4	6	1/2" UNF
9130	375	25.4	50	51.3	6.4	25		M12 x 1.75
9133	375	25.4	50	50.5	6.4	25	6	M12 x 1.75
9134	375	25.4	50.8	50.5	6.4	25.4	6	1/2" UNF
9135	375	25.4	50.8	42	6.4	60	10	1" UNF
9140	1100	38.1	60	73.5	12.7	40		M20 x 2.5
9143	1100	38.1	60	71.5	12.7	40	10	M20 x 2.5
9144	1100	38.1	60.3	71.5	12.7	38.1	10	3/4" UNF
9145	1100	38.1	60.3	60	12.7	75	6	1" UNF
9150	2200	50.8	100	105	14.3	54		M24 x 3.0
9153	2200	50.8	100	109	14.3	50	10.6	M24 x 3.0
9154	2200	50.8	101.6	109	14.3	50.8	10.6	1" UNF
9160	4550	76.2	160	145	21	57.2		1" UNF
9163	4550	76.2	160	145	21	100	15	M30 x 3.5

* further 1.5mm @ 16.2mm outside Ø

91 Series units omit drain/debris channel - contact us if required

91 SERIES
ENDING 0, 1 & 2

OTHERS

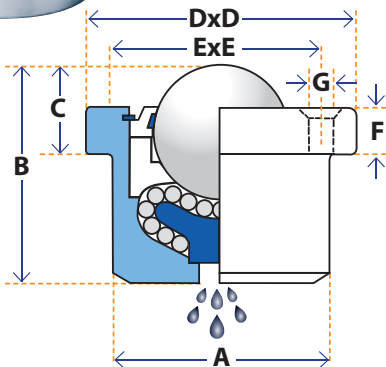
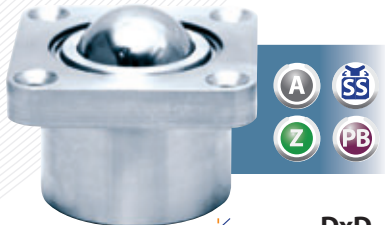
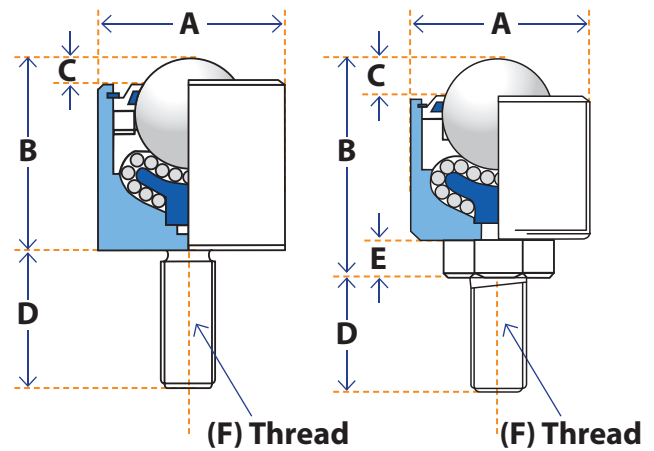

93 Series - *FLANGE SOCKET*

Part No	Load (kg)	Ball Ø mm	A	B	C	D x D	E x E	F	G Ø
9300	46	12.7	23.8	22.2	11.2	44.5 ø♦	34.9	3.2	2 x 3.6
9310	46	12.7	23.8	22.2	7.9	47.7 x 32*	34.9	2	2 x 4 ▼
9320	225	25.4	44	41.3	10.3	57.2	44.5	4.8	4 x 6.1
9321	225	25.4	44.5	41.3	11.9	57.2	44.5	4.8	4 x 6.1
9330	375	25.4	50	44.5	12.7	76.2	57.9	6.4	4 x 8.1
9341	1100	38.1	60	60	25.4	76.2	57.9	12.7	4 x 8.1
9350	2200	50.8	100	95	33.3	127	101.6	19.1	4 x 11.1
9351	2200	50.8	101.6	98.4	36.5	127	101.6	22.2	4 x 11.1
9352	2200	50.8	109.5	98.4	33.3	127	101.6	19.1	4 x 10.2 ▼
9360	4550	76.2	160	145	36	175	145	15	4 x 12.1

♦ 9300 - Circular flange * 9310 - Elliptical flange
▼ Not countersunk

98 Series - *TOLERANCE RING*

Part No	Load (kg)	Ball Ø mm	A	B	C	D	E	F
9810	46	12.7	22*	12	6	21	24	2.4
9820	225	25.4	45*	15	14	40	49	6.9
9830	375	25.4	50*	16	15	44	55	8.6
9840	1100	38.1	65*	20	25	60	70	12.3
9850	2200	50.8	100*	24	30	95	110	15.7

* Bore Ø to ISO H9 fit

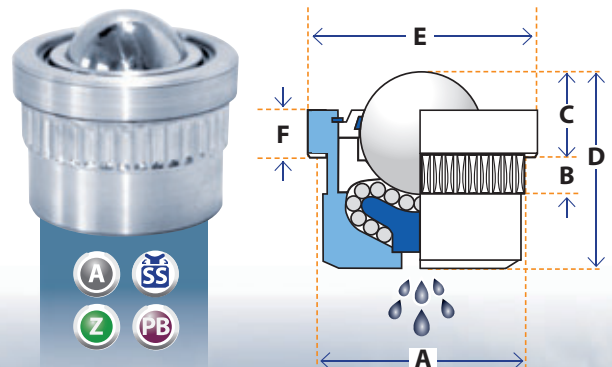



HIGH CAPACITY RANGE - Spring Loaded Range

Low Friction



1: 0,005

Speed



2 m/sec

Temperature



-50 to 160 °C

Orientation



ANY

High Shock



Resistance

Uneven



Loads

User



Serviceable ▼

▼ = Not applicable on units with Ball Ø 12.7mm

High Capacity Spring Loaded units are ideal where uneven track conditions or shock loading occurs. 95, 96 & 97 Series offer full retraction of the main ball within the housing. Extended service life & user serviceable with full spares back-up. Consider alternative material upgrade options to withstand the most severe operating environments.

Standard Materials - high grade AISI 52100 chrome steel Balls & zinc plated carbon steel housing		Corrosion Resistance	Contaminated Environment	Temperature		Radiation Resistance
Solve specific application requirements by upgrading materials - select option by adding suffix				Low	High	
A	= Stainless Steel Balls (AISI 440) but other materials as Standard	✓	✓	✓	✓	✓
Z	= 'Arduous Conditions' Stainless Steel (AISI440) internal parts & Balls. "Anti-Oxide" finish to steel casing. Spring mechanism parts in carbon steel	✓✓	✓✓	✓✓	✓	✓
SS	= Stainless Steel internal parts & Balls AISI440, housing AISI 304. Spring mechanism parts in carbon spring steel	✓✓✓	✓✓✓	✓✓✓	✓✓✓	✓✓✓

94 Series - EXTERNAL SPRING LOADED



Part No	Ball Ø mm	Pre-load kg	Max deflect rec' md	Load at max deflection kg	A	B	C	D	E	Fixing Holes (PCD)	G
9401	12.7	7	2	32	20.6	32.2	47.0	14.7	20		3.8 ~
9402	12.7	14	2	35	20.6	31.8	47.0	14.7	20		3.8 ~
9403	12.7	23	2	38	20.6	32.2	47.0	14.7	20		3.8 ~
9404	12.7	23	2	38	20	32.2	47.0	14.7	20		3.8 ~
9410	12.7	7	2	32	22.2	39	47.0	14.7	20		3.8 ~
9411	12.7	14	2	35	22.2	38.6	47.0	14.7	20		3.8 ~
9412	12.7	23	2	38	22.2	39	47.0	14.7	20		3.8 ~
9420	25.4	7	5.4	136	44.5	61.9	77	19.2	31.8	3 x M5 (24.8)	5.6
9421	25.4	23	5	136	44.5	61.5	77	19.2	31.8	3 x M5 (24.8)	5.6
9422	25.4	45	4.4	136	44.5	60.9	77	19.2	31.8	3 x M5 (24.8)	5.6
9423	25.4	68	5.3	136	44.5	61.8	77	19.2	31.8	3 x M5 (24.8)	5.6
9424	25.4	89	2.7	204	44.5	61.5	77	19.2	31.8	3 x M5 (24.8)	5.6
9425	25.4	109	2.6	204	44	63	77	19.2	31.8	3 x M5 (24.8)	5.6
9430	25.4	91	7.7	331	50.8	80.8	95.3	19.2	38.1	3 x M6 (29)	6.4
9431	25.4	136	6.5	331	50.8	79.6	95.3	19.2	38.1	3 x M6 (29)	6.4
9432	25.4	181	5.8	331	50.8	80.5	95.3	19.2	38.1	3 x M6 (29)	6.4
9433	25.4	227	4.6	331	50.8	81	95.3	19.2	38.1	3 x M6 (29)	6.4
9440	38.1	227	10.5	960	60.3	115	162.1	35	59.4	3xM6 (50.8)	12.7
9441	38.1	318	11.1	960	60.3	121	162.1	35	59.4	3xM6 (50.8)	12.7
9442	38.1	454	11.1	960	60.3	129.2	162.1	35	59.4	3xM6 (50.8)	12.7
9443	38.1	567	8.8	960	60.3	126.9	162.1	35	59.4	3xM6 (50.8)	12.7
9444	38.1	680	9.2	960	60.3	146.3	189.7	35	59.4	3xM6 (50.8)	12.7
9445	38.1	748	8.2	960	60.3	156.2	189.7	35	59.4	3xM6 (50.8)	12.7
9450	50.8	764	2	1400	101.6	139.1	160.3	50.8	101.6	4 x M8 (76.2)	14.3
9451	50.8	764	5.3	1400	101.6	175.1	200.9	57	101.6	4 x M8 (76.2)	14.3
9452	50.8	1018	6	1400	101.6	177.4	200.9	57	101.6	4 x M8 (76.2)	14.3
9453	50.8	1273	5.9	1800	101.6	174.6	200.9	57	101.6	4 x M8 (76.2)	14.3
9454	50.8	1364	2.5	2000	101.6	137	158.4	50.8	101.6	4 x M8 (76.2)	14.3
9455	50.8	1527	5.7	2036	101.6	171.5	200.9	57	101.6	4 x M8 (76.2)	14.3

~ further 1.5mm @ 16.2mm outside Ø

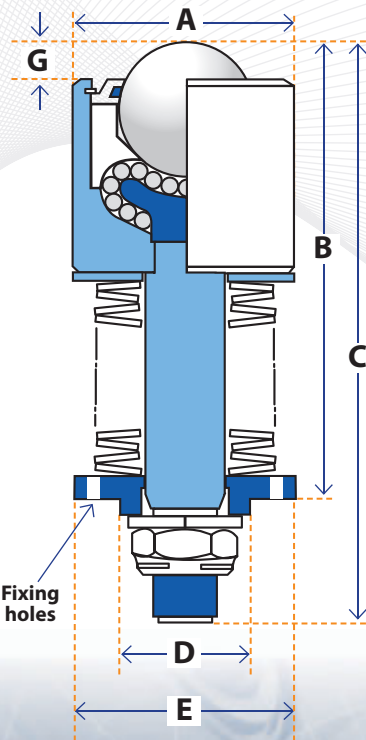

Fixing holes



HIGH CAPACITY RANGE - Spring Loaded Range



95 Series - HOUSED SPRING LOADED

Part No	Supports Load kg	Deflection mm	Load at Max Deflection kg	Ball Ø	A	B
9500	23	2.2	38	12.7	25.4 *	25.4
9501	12	3.3	46	12.7	25.4 *	25.4
9520	91	4.8	188	25.4	50.8	55.5
9530	227	2.4	367	25.4	63.5	60.3
9540	450	10	960	38.1	69.9	114.3
9550	1000	6.1	2000	50.8	120	138.9

* 8mm wide (fine) knurl on outside Ø

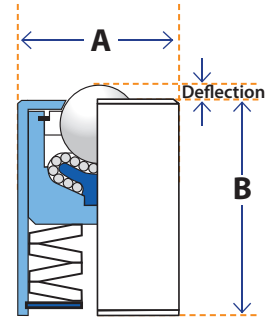

96 Series - FLANGE SOCKET SPRING LOADED

Part No	Supports Load kg	Deflection mm	Load at Max Deflection kg	Ball Ø	A	B	C	D	E (PCD)	F (Counter-sunk)
9601	12	3.3	46	12.7	5	25.4	25.4	50	36	2 x 5.1
9620	91	4.8	188	25.4	6	55.5	50.8	80	65	3 x 6.1
9630	227	2.4	367	25.4	6	60.3	63.5	100	80	3 x 8.1
9640	450	10	960	38.1	10	114.3	69.9	115	92	3 x 10.1
9650	1000	6.1	2000	50.8	12	138.9	120	165	140	3 x 10.1

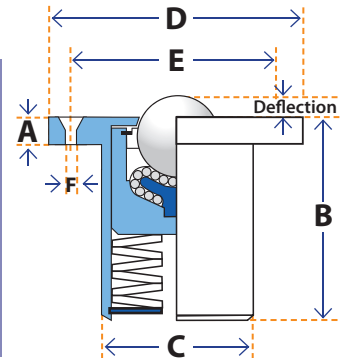

97 Series - FLANGE MOUNTED SPRING LOADED

Part No	Supports Load kg	Deflection mm	Load at Max Deflection kg	Ball Ø	A	B	C	D	E (PCD)	F (Counter-sunk)
9701	12	3.3	46	12.7	5	25.4	25.4	50	36	2 x 5.1
9720	91	4.8	188	25.4	6	55.5	50.8	80	65	3 x 6.1
9730	227	2.4	367	25.4	6	60.3	63.5	100	80	3 x 8.1
9740	450	10	960	38.1	10	114.3	69.9	115	92	3 x 10.1
9750	1000	6.1	2000	50.8	12	138.9	120	165	140	3 x 10.1

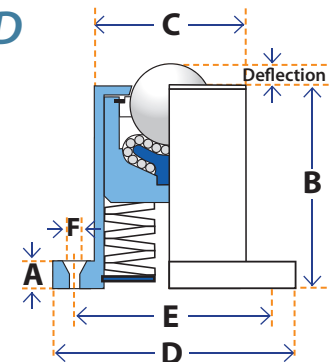

T-BARS & B-BARS

'T' & 'B' Bars incorporate heavy-duty spring-loaded ball units for accurate positioning & effortless conveying of tools & dies on press & machine beds. Once positioned, clamp the tool & the springs allow the ball units to retract beneath the bed. Unclamp & the ball units will raise the tool above the bed ready to convey again. 'T' bars feature an integral locking mechanism - 'B' bars are locked using recessed M8 cap screw (requires drilling & tapping of the bed). Custom sizes available.

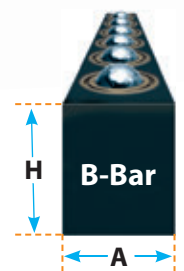
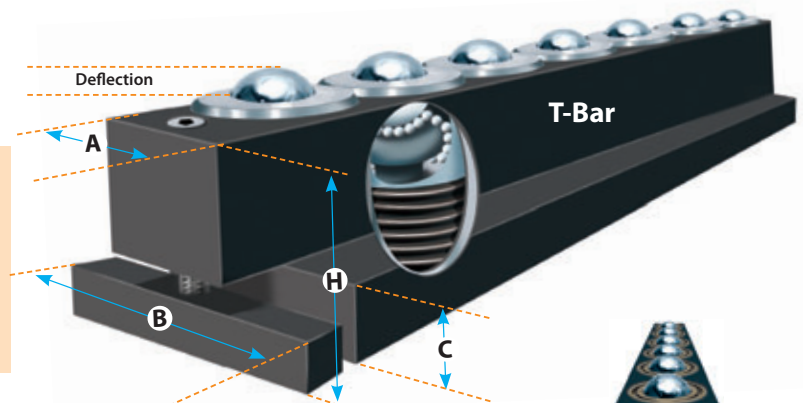

Bar	A	B	C	H	Bar Length	Supports Loads/ Bar kg	Deflection mm	Load at Max Deflection kg	No of Ball Units
T-20	20	34	10	35	300	224	2.6	352	8
T-22	22	37	16	38	343	252	2.6	396	9
T-24	24	42	18	42	415	280	2.6	440	10
T-28	28	46	20	48	305	308	2.6	484	11
T-36	36	56	25	61	345	252	2.6	396	9
B-21	20.6			25.4	250	168	2.6	264	6
B-22	22.2			30.1	395	224	2.6	352	8
B-25	25.4			38.1	350	305	2.6	484	11





MEDIUM DUTY RANGE

Low Friction



1: 0,02

Speed



1.5 m/sec

Temperature



-30 to 100 °C

Orientation



Horizontal/Ball 'up'

Shock



Resistance

Medium Duty 'Metric' ball units are machined from solid steel bar & hardened for heavy load capacity & wear resistance. Reinforced machined steel top cap protects against impact from misalignment of the conveyed item. Main ball sizes larger than 19mm incorporate a felt seal to minimise contamination. Lubricated for life. 'M' and 'MG' series are fitted with single drain hole.

Standard Materials - Chrome steel AISI 52100 Balls.
Machined AISI 1016 steel housing, toughened & zinc plated
Solve specific application requirements by upgrading materials - select option by adding suffix

A = Stainless Steel Balls (AISI 420) but other materials as Standard. Reduce load by 30%

SS = All parts in Stainless Steel - outer housing AISI 416, Balls AISI 420. Reduce load by 30%

D = Acetal (POM) main ball option - reduce load - see chart in Technical Reference page 10



C = **Separate fixing clip** assists installation & compensates for irregular bore Ø for units with main ball Ø 15, 22 & 30 mm. Secure clip to bore & then pass unit through clip.



Part N°	Ball size Ø	Minimum Bore Ø	Maximum Bore Ø
C15	15	24.8	25
C22	22	37	37.2
C30	30	46.3	46.7

Clip requires a minimum plate thickness of 3 mm to grip securely

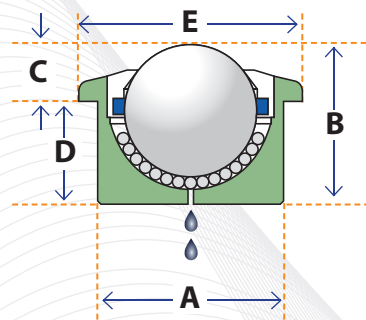
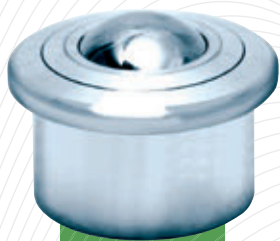

M Series - PUSH FIT

Part No	Max Load kg	Ball Ø	A	B	C	D	E
M12 *	20	12	22	16.7	8	8.7	27
M14	50	15	24	20	8.1	11.9	30
M15 *	50	15	24	21	9.5	11.5	31
M22	180	22	36	30.5	9.8	20.7	45
M25 *	200	25	38	30.5	13	17.5	46
M30	350	30	45	36.8	13.8	23	55
M45	600	45	62	53.5	19	34.5	75
M60	1500	60	100	78	30	48	117

* Denotes pressed top cap.

MG Series - PLAIN FITTING

Part No	Max Load kg	Ball Ø	A	B	C	D
MG8 *	12	8	18	12	10	2
MG10	20	12	20	16.5	13.5	3
MG12 *	20	12	22	17.5	14	3.5
MG15	50	15	24	20	15	5
MG22	180	22	36	30.5	27.9	2.6
MG30	350	30	45	36.8	30.3	6.5
MG45	600	45	62	53.5	45	8.5
MG60	1500	60	100	77.5	61	16.5
MG76	2500	76	130	103	80	23
MG90	3500	90	145	115	90	25

* Denotes pressed top cap.

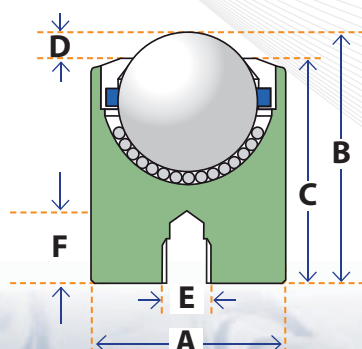
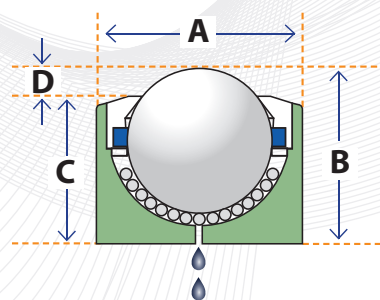

MI Series - INTERNAL THREAD FIXING

Part No	Max Load kg	Ball Ø	A	B	C	D	E	F
MI12 *	20	12	22	24	20.5	3.5	M8 x 1.25	5
MI15	50	15	24	28	23	5	M8 x 1.25	8
MI22	180	22	36	40.5	34	6.5	M8 x 1.25	10
MI30	350	30	45	46.8	38.8	8	M8 x 1.25	10
MI45	600	45	62	63.5	50.5	13	M8 x 1.25	10

* Denotes pressed top cap.



MSP Series - BOLT FITTING

Part No	Max Load kg	Ball Ø	A	B	C	D	E	F
MSP10	20	12	20	29.8	17.8	3	12	M8 x 1.25
MSP11	25	12	20	48	20	3	28	M6 x 1.0
MSP12 *	20	12	22	42.5	22.5	3.5	20	M8 x 1.25
MSP14	50	15	24	32.5	20.5	3.9	12	M6 x 1.0
MSP15 *	50	15	25	46	26	5	20	M8 x 1.25
MSP19	75	19	30	46.5	26	4.8	20.5	M8 x 1.25
MSP22	180	22	36	62.9	37.5	2.6	25.4	M12 x 1.75
MSP30	350	30	45	69.2	43.8	6.5	25.4	M12 x 1.75
MSP45	600	45	62	107.3	66	8.5	41.3	M20 x 2.5

* Denotes pressed top cap.

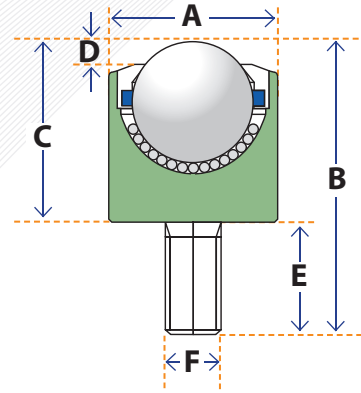

MS Series - TOP FLANGE

Part No	Max Load kg	Ball Ø	A	B	C	D x D	E x E	F	G
MS12 *	20	12	23.9	9.6	11.1	44.5#	34.9	3.2	2 x 3.6
MS15 *	50	15	24	11.3	9.7	45	32	4.8	4 x 4.6
MS22	180	22	36	11.8	18.7	57.2	44.5	4.8	4 x 5.6
MS30	350	30	45	16.8	20	76.2	57.9	6.3	4 x 7.1
MS45	600	45	62	22	31.5	85	69	9.5	4 x 7.1

MS 12 has a 44.5mm circular flange with 2 mounting holes.

* Denotes pressed top cap.

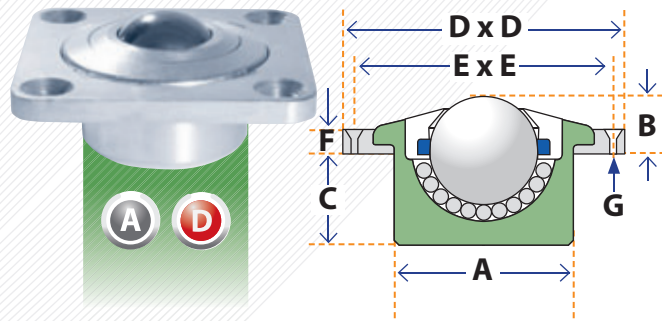

MF Series - BOTTOM FLANGE

Part No	Max Load kg	Ball Ø	A	B	C	D	E x E	F x F	G	H
MF12 *	20	12	23.9	20.7	17.2	3.5	44.5#	34.9	3.2	2 x 3.6
MF15 *	50	15	25	21	16	5	45	32	4.8	4 x 4.6
MF22	180	22	36	30.5	27.9	2.6	57.2	44.5	4.8	4 x 5.6
MF30	350	30	45	36.8	30.3	6.5	76.2	57.9	6.3	4 x 7.1
MF45	600	45	62	53.5	45	8.5	85	69	6.3	4 x 7.1

MF 12 has a 44.5mm circular flange with 2 mounting holes. * Denotes pressed top cap.

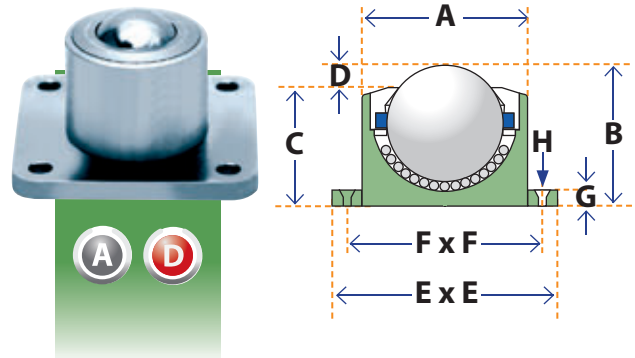

MO Series - 'O' RING FITTING

Part No	Max Load kg	Ball Ø	A	B	C	D	E	F
MO15 *	50	15	24	21	11.5	9.5	2	31
MO22	180	22	36	30.5	20.7	9.8	3	45
MO30	350	30	45	36.8	23	13.8	4	55
MO45	600	45	62	53.5	34.5	19	5	75

* Denotes pressed top cap.

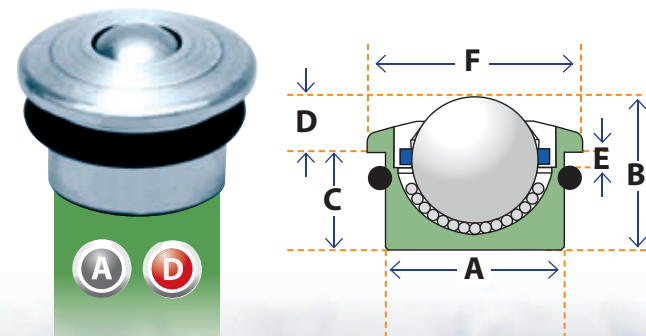

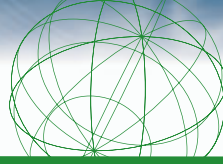

MEDIUM DUTY RANGE

Low Friction



1: 0,02

Speed



1.5 m/sec

Temperature



-30 to 100 °C

Orientation



Horizontal/Ball 'up'

Shock



Resistance

A = Stainless Steel Balls (AISI 420) but other materials as Standard

SS = Internal ball unit parts in Stainless Steel AISI 420. Outer housing & spring parts in Carbon Steel



MN/MM Series - MEDIUM SPRING HOUSED

Part No	Max Load kg	Deflection mm	Load at Max Deflection kg	Ball Ø	A	B	C	D	E
MN22	100	1.5	120	22	48		39.9		46.5
MM22	70	4.5	90	22	58	14	39	50	53.5
MM30	135	7	170	30	70	17.5	48.5	62	63
MM45	230	10.5	290	45	100.5	25.5	66.5	85	90

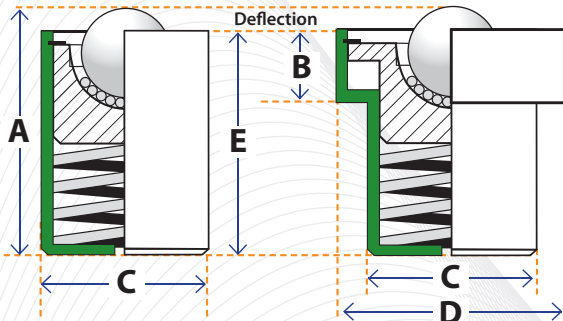

Alternatives

Other spring-loaded solutions for ball 'up' & 'down' orientations – see High Capacity 94, 95 & 96 ranges (pages 5 & 6)

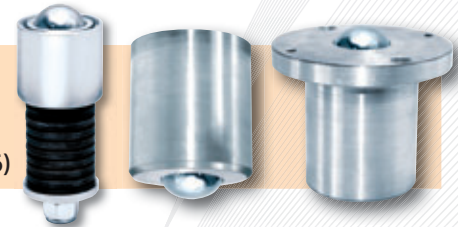

MX 'Extreme' & MW 'Washdown' Series



	High Temperature	Liquid Drainage	Load Capacity	Shock Resistance	Stainless Steel Support Cup
MX	✓	✓	✓✓	✓✓	
MW	✓✓	✓✓	✓	✓	✓✓

All feature Stainless Steel (AISI 420) balls within a durable solid machined casing.

Extreme MX Series housing is case hardened for maximum load capacity & resistance to shock loads. Large debris/drain channels eject contamination & fluid easily. MX30 available with optional separate fixing clip (add suffix 'C'). Both models with all Stainless Steel (AISI 420) parts, add suffix 'SS'.

Washdown MW Series features stainless steel support cup throughout the internal hemispherical working area for maximum corrosion resistance & draining in Washdown applications. MW30 available with optional separate fixing clip (add suffix 'C').

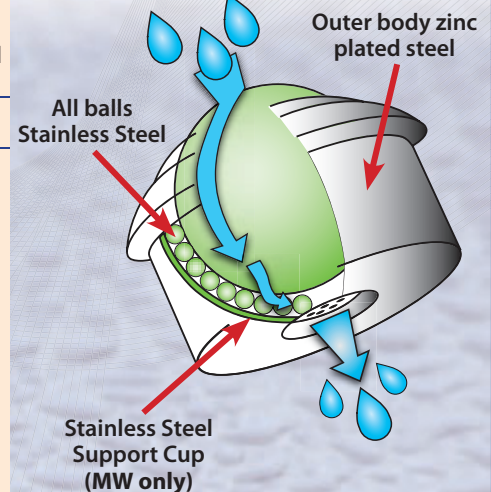

Part No	Max Load kg	Ball Ø	A	B	C	D	Drain holes	Weight kg
MX 30	350	30	45	13.8	23	55	7	0.36
MW30	220	30	45	13.8	23	55	5	0.33
MX 30-C	350	30	46.3 - 46.7	14.1	22.7	55	7	0.36
MW30-C	220	30	46.3 - 46.7	14.1	22.7	55	5	0.33
MX 45	600	45	62	19	34.5	75	7	0.99
MW45	450	45	62	19	34.5	75	1	0.99

MW30-C & MX30-C B & C change when using fixing clip

C Add suffix 'C' for fixing clip, MX30 & MW30 only.

SS All parts in AISI 420 Stainless Steel. Reduce load by 30%.

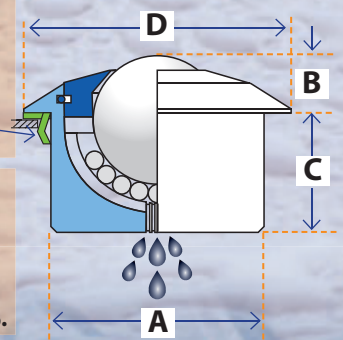

WHICH MEDIA?	Max Load	Friction	Speed	Shock loads		Arduous conditions		Orientation	Instant change
	kg	% of Load	m/second	94-97 Series	90-93 & 98 Series	✓/✓	Z' & 'SS' options	Orientation icons	✓/✓/✓
High Capacity	46-4550	0.5 %	2	✓✓✓+	✓✓✓	✓✓	Z' & 'SS' options	Orientation icons	✓✓✓
Medium Duty	20-3500	2 %	1.5	✓✓✓	✓✓	✓✓	MW & 'SS' option	Orientation icons	✓✓✓
Light Duty	7-250	3 %	1	✓	LM series	✓✓	'SS' options	Orientation icons	✓✓✓
Omniball	30 & 60	3 %	1		✓	✓✓✓		Orientation icons	✓✓
Omnwheel	8 & 25	5 %	1		✓	✓✓✓		Orientation icons	✓
Omnifloat	18 & 22	6 %	1		✓	✓✓✓		Orientation icons	✓

LOAD & STABILITY

To determine the load each Ball Unit will need to support

Flat surfaces

Load = 1000 Kg (3 x 1000 Kg units minimum)

Uneven surfaces

Load x 3 = 9000 Kg (eg. 9 x 1000 Kg units)

PITCH & SPACING

Solid items

Narrowest width ÷ 3.5

Deformable items

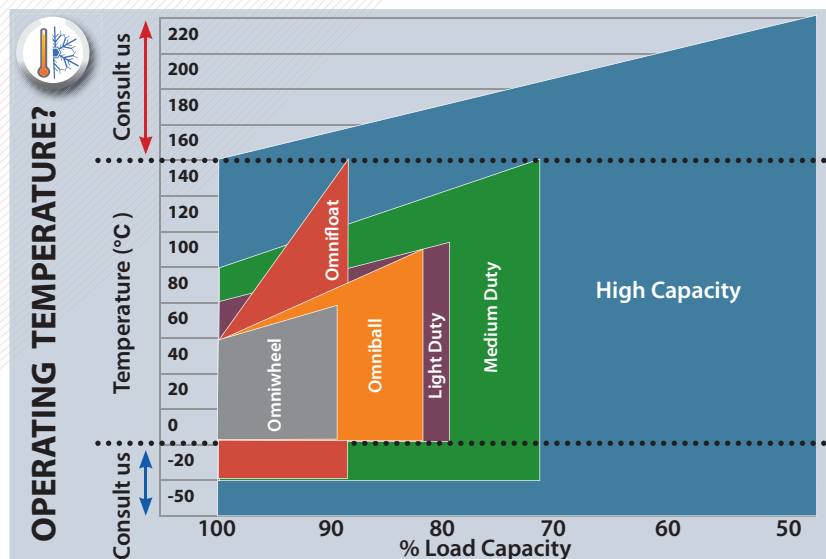

HIGH CAPACITY RANGE - DEBRIS & DRAIN CHANNELS

All units (main ball > 12.7mm)

Standard & A

1 x drain channel

Z & SS
2 x drain channels

ALSO CONSIDER:

- STABILITY** – Support item on a minimum of three points
- SHOCK LOADS** – Specify High Capacity series & spring loaded units
- TRACK HARDNESS/CONVEYED ITEM MATERIAL** – Standard material ball units have Rockwell 'C' hardness of 60 minimum
- DELICATE SURFACES** – Ball Units - Acetal (POM) & Phenolic Resin, Omniball, Omnifloat & Omnwheel options
- OPERATING ENVIRONMENT** – Wet, Dirty, Outdoor, Radioactive
- SERVICE LIFE** - User servicing & Service kits available for most High Capacity units. Omnifloat spares also available – see page 2

Ball Units with alternative ball materials – Load capacity

Main Ball Ø	12/12.7	15	19	22	25/25.4	30	38.1	45
Acetal (POM)	4	10	20	20	25	25	25	-
Phenolic Resin	5	-	-	22	30	35	35	35
AISI 420 Stainless Steel	Derate load by 30% unless stated							
AISI 440 Stainless Steel	Max load as Standard Materials							

SUPPORT & BUY



Amcats Pvt. Ltd.

+91-22-61464444

sales@amcats.com

+91-22-25564987

www.omnitrack.in

- No minimum order
- Immediate dispatch (most items)
- Free technical advice
- 'Specials' no problem, in-house production



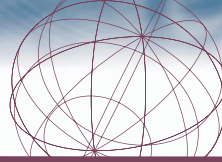

LIGHT DUTY RANGE

Low Friction



1:0,03

Speed



1 m/sec

Temperature



-20 to 70 °C

Orientation



Horizontal/Ball 'up'

Economy



Value

Light duty units are ideal for conveying applications requiring ball 'up' orientation. LP 'Plastic' units are non-magnetic, lightweight & offer complete corrosion resistance.

Pressed steel units are lubricated for life & most types have alternative material options to suit service in diverse operating environments.

Standard Materials - zinc plated pressed AISI 1040 steel housing with AISI 52100 steel Balls (except 'LP' range)

A = Stainless steel AISI 420 Balls with zinc plated pressed AISI 1040 steel housing (except 'LP' range)

SS = All parts in Stainless Steel – Balls AISI 420. Outer housing AISI 416

D = Acetal (POM) main ball option. Note: reduced load capacity

C = Separate fixing clip assists installation & compensates for irregular bore Ø. Secure clip to bore & then pass unit through clip

LD - SATURN TYPE RANGE

Part No	Max Load kg	Ball Ø	A	B	C	D	E	F
LD15	20	15	35.2	19.1	9.5	23.9		
LD16	15	15	41	19.3	10.8	24	30	2 x 3.4
LD16-A	10	15	41	19.3	10.8	24	30	2 x 3.4
LD16-D	10	15	41	19.3	10.8	24	30	2 x 3.4
LD23	120	22	45	27.7	9.8	33	39	3 x 3.5
LD23-A	90	22	45	27.7	9.8	33	39	3 x 3.5
LD23-D	22	22	45	27.7	9.8	33	39	3 x 3.5
LD25-SS	55	25	47.1	29.6	14.3	38.1		
LD26	60	25	56	30	14.6	36	45	2 x 4.0
LD26-A	40	25	56	30	14.6	36	45	2 x 4.0
LD26-D	22	25	56	30	14.6	36	45	2 x 4.0
LD32-SS	125	32	74	36	16.2	46	58.7	2 x 5.5
LD32/3-SS	125	32	74	36	16.2	46	58.7	3 x 5.5

LD32-SS & LD32/3-SS units feature 7 large fluid drain holes & omit felt seal.

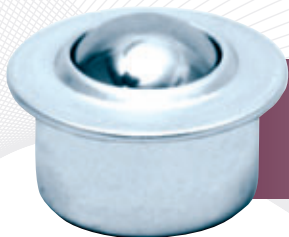
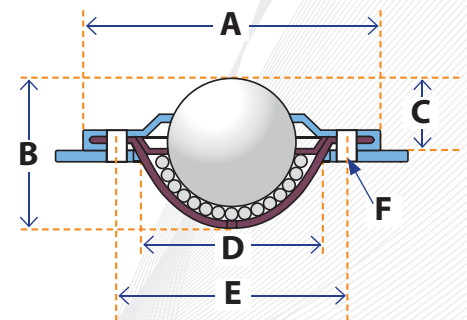

Fixing Clip

All 'L' range models can be supplied with a separate Stainless Steel fixing clip (add suffix 'C')

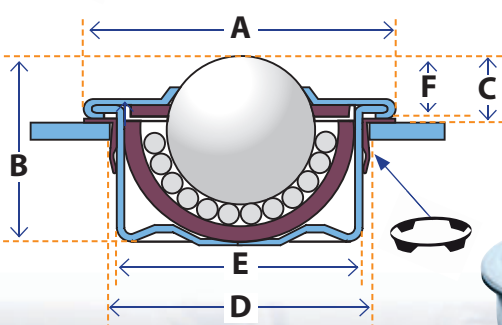

L - PUSH FIT RANGE

Part No	Max Load kg	Ball Ø	A	B	C	D	E	F
L15	50	15	31	21	9.8	24.8-25	24	9.5
L22	160	22	45	29.5	10.1	37-37.3	36	9.8
L30	250	30	55	37	14.1	46.3-46.7	45	13.8
L15-A	60	15	31	21	9.8	24.8-25	24	9.5
L22-A	150	22	45	29.5	10.1	37-37.3	36	9.8
L30-A	250	30	55	37	14.1	46.3-46.7	45	13.8
L15-SS	40	15	31	21	9.8	24.8-25	24	9.5
L22-SS	90	22	45	29.5	10.1	37-37.3	36	9.8
L30-SS	180	30	55	37	14.1	46.3-46.7	45	13.8
L15-D	10	15	31	21	9.8	24.8-25	24	9.5
L22-D	20	22	45	29.5	10.1	37-37.3	36	9.8
L30-D	25	30	55	37	14.1	46.3-46.7	45	13.8

All variants with 22mm & 30mm main balls feature a felt seal.

To compensate for irregularities in bore & diameter, specify the separate spring clip option (by adding suffix 'C'). Firstly fit the clip to the bore & subsequently push the ball unit through the clip. As the ball unit passes through the clip, peripheral tags expand & retain the ball unit whilst also securely gripping the inside diameter of the bore





LIGHT DUTY RANGE

Low Friction



1: 0,03

Speed



1 m/sec

Temperature



-20 to 70 °C

Orientation



Horizontal/Ball 'up'

Economy



Value

Standard Materials - zinc plated pressed AISI 1040 steel housing with AISI 52100 steel Balls (except 'LP' range)

A = Stainless Steel AISI 420 Balls with zinc plated pressed AISI 1040 steel housing (except 'LP' range)

SS = All parts in Stainless Steel - Balls AISI 420. Outer housing AISI 416

D = Acetal (POM) main ball option. Note: reduced load capacity

C = Separate fixing clip assists installation & compensates for irregular bore Ø. Secure clip to bore & then pass unit through clip

LF25

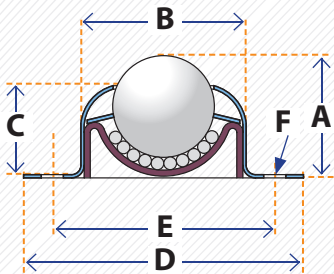

LF - FLANGE MOUNTED 2 & 4 HOLE FITTING

Part No	Max Load kg	Ball Ø	A	B	C	D	E	F
LF25	55	25.4	30.2	42	22.2	69.9 x 50.8	55.6	2 x 5.6 Ø
LF38	115	38.1	46	66.7	36.2	76.2 x 76.2	62.7 x 62.7	4 x 7.1 Ø

Zinc plated, pressed steel construction, flange mounted units with either 2 or 4 fixing holes. Robust & economical solution to surface mount conveying applications

LF38

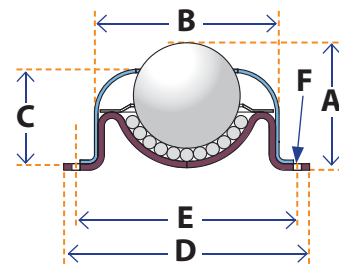

LM - CASED SPRING LOADED

Part No	Support Load kg	Deflection mm	Load at max Deflection	Ball Ø	A	B	C	D	E
LM25	20	4.5	55	25.4	43.5	49.1	35.7	10.1	15.7

Versatile spring loaded unit with integral moulded nylon seal & zinc plated pressings for corrosion resistance

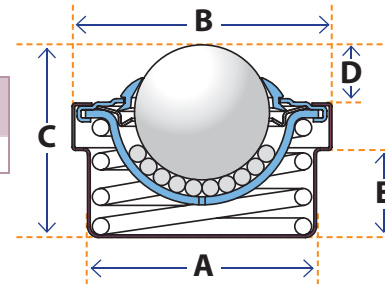

LP - PLASTIC UNITS

Part No	Max Load kg	Ball Ø	A	B	C	D	E	Weight kg
LP15	7	15	24	21	9.5	11.5	31	0.012
LP15A	7	15	24	21	9.5	11.5	31	0.024
LP22	10	22	36	30.5	9.8	20.7	45	0.036
LP22A	10	22	36	30.5	9.8	20.7	45	0.074
LP30	15	30	45	37	13.8	23	55	0.066
LP30A	15	30	45	37	13.8	23	55	0.162
LP45	20	45	62	53.5	19	34.5	75	0.176
LP45A	20	45	62	53.5	19	34.5	75	0.502

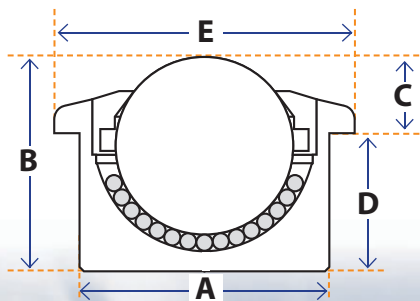

Housing made from Acetal (POM) & available with either Acetal (POM) or AISI 316 Stainless Steel balls (add suffix 'A')

- Resists salt water & chemical attack
- Low weight & friction
- Non conductive & non magnetic
- Suited to antimicrobial applications

Fixing Clip
All LP15, LP22 & LP30 models can be supplied with a separate Stainless Steel fixing clip (add suffix 'C')





MOVEMENT SOLUTIONS

omniball™

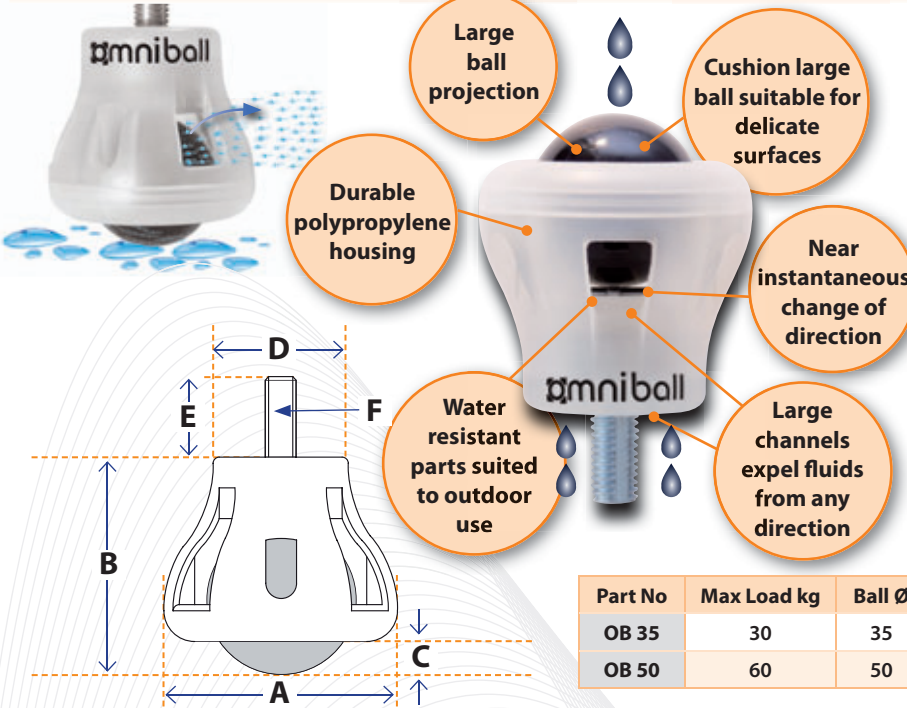
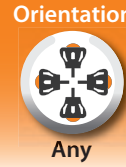
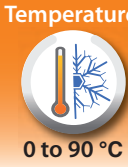

Patented, innovative design provides a new castor with a far reduced 'trail' for near instantaneous directional change. Convey or glide easily over fragile, uneven or soft materials such as wood, carpet or glass whilst minimising damage to flooring or the conveyed item.

Multiple drain channels expel debris & fluids during use at any angle of operation making Omniball ideal in highly contaminated & washdown areas. Suited to temperatures of up to 90°C thus providing an improved alternative to glass handling, industrial process applications & furniture design. Standard colour black - others available upon request.



Part No	Max Load kg	Ball Ø	A	B	C	D	E	F
OB 35	30	35	60	60.5	10	44 Ø	25	M10 x 1.5
OB 50	60	50	75	77	17.5	44 Ø	25	M10 x 1.5

omniwheel™

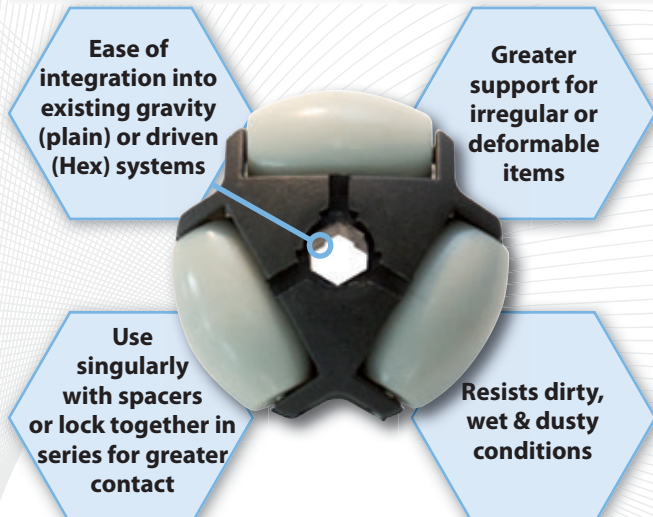
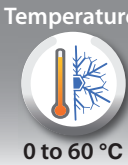

Omniwheels have 3 peripheral polyamide rollers rotating on stainless steel axles ideal for assembly lines, machine feed & packing areas.

- Plain diameter bore for gravity fed conveyor systems
- Hexagon centre (suffix '-H') for driven conveyors

Lock Omniwheels together in series for 360 degree support across narrow or irregular shaped items. Use singularly for items with larger surface areas when combined with spacer tubes.

We supply polypropylene spacer tubes pre-cut to required lengths - alternative materials available upon request.

Part No	Max Load kg	Wheel Ø	A	B	C	D	E
OW48	8	48	21.5	3	3	40	Ø 8.2
OW48-H	8	48	21.5	3	3	40	8.1 HEX DRIVE
OW80	25	80	34	4	4	65	Ø 12.2
OW80-H	25	80	34	4	4	65	11.2 HEX DRIVE

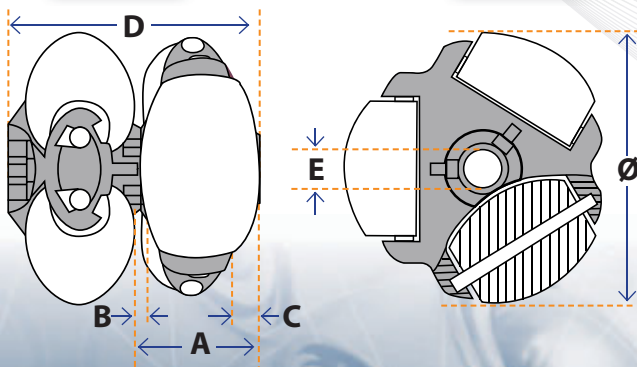

Configuration options





MOVEMENT SOLUTIONS

omni float™

Low Friction	Speed 1.5 m/sec	Temperature -20 to 150 °C	Orientation Any	Delicate Contact	Water Resistant	Outdoor Application
--------------	-----------------	---------------------------	-----------------	------------------	-----------------	---------------------

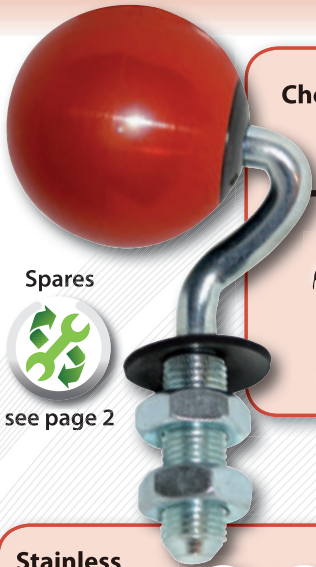

Choose the Ball material for your application:

- Rubber Ball add suffix 'R'**
= Better Grip (Black)
70 Shore 'A' -20°C to +80°C
- Polyurethane Ball add suffix 'P'**
= Wear resistant (Caramel)
92 Shore 'A' -20°C to +80°C
- High Temperature add suffix 'HT'**
= Heat resistant (Red)
80 Shore 'A' -20°C to +150°C

Omnifloat castors allow smooth, safe conveying & directional changes whilst protecting delicate or polished surfaces. These strong & practical castors permit easy handling of sheet materials such as glass in wet, corrosive, dusty & high temperature conditions.

Omnifloats are typically supplied with a 50% mix of 'left hand' & 'right hand' swivel trail. We recommend fitting the castors in a regular alternate pattern to minimise bias & provide a neutral conveying plane.

Replacement balls available as spares. Alternative materials can be retro-fitted for extended durability & service - see page 2 for details.

Spares
see page 2

Stainless Steel Arm Upgrade

Corrosion/Chemical attack?
Specify Stainless Steel Arm (AISI 304)
Standard materials are zinc plated steel arm (AISI 1113)

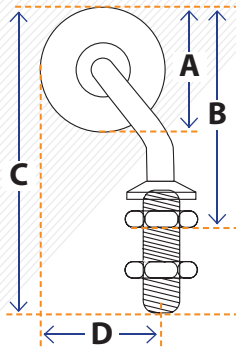

To Order:

- Select model: OF35-55 / OF35-75 / OF50-100
- Specify Ball material: 'R'= Rubber / 'P'= Polyurethane / 'HT'= High Temperature (i.e. OF35-75HT)
- Stainless Steel Arm required? Add suffix 'SS' (otherwise zinc plated steel arm)

Omnifloat	A	B (min-max)	C	D	Thread	Load Rating
OF 35-55	35	54-76	92	27.5	M14 x2.0	18kg
OF 35-75	35	54-71	87	37.5	M14 x2.0	18kg
OF 50-100	50	69-91	107	50	M14 x2.0	22kg

omnitable™

--	--	--	--	--	--	--

Custom made tables, mats & turntables to suit your conveying needs

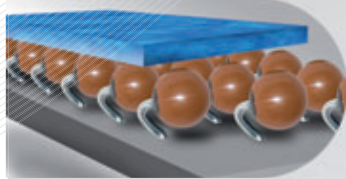

	Heavy load/Shock	Instant directional change	Dirty Conditions	Irregular non-sturdy items	Delicate Contact	User Serviceable
Omnitrack	✓✓✓	✓✓✓	✓	✓✓	✓	✓✓✓
Omniball	✓✓	✓✓	✓✓✓	✓✓	✓✓	✓
Omniewheel	✓	✓✓	✓✓✓	✓✓✓	✓✓✓	✓
Omnifloat	✓	✓	✓✓	✓	✓✓✓	✓✓✓

We'll help you devise your bespoke solution by choosing the most appropriate media

Key considerations:

- Overall dimensions of table area
- Minimum/maximum dimensions & weight of the conveyed items
- Material & finish of the conveyed item
- Operating environment where the table will be sited (outdoors, refrigerated conditions, hygienic areas)
- Rigidity, flatness, density & fragility of the conveyed items
- Special operations - washdown conditions, speed, assembly procedures

Choose your pitch:

Elongated pitch		Square pitch		Diamond pitch	
-----------------	--	--------------	--	---------------	--

omnitrack™

OMNI-DIRECTIONAL MOVEMENT SOLUTIONS

omnitrack™



- Low Friction
- Heavy Load
- Precision Long Life
- Shock Loading

omniball™



- Fast Directional Change
- Outdoor Use
- Wet & Dirty Conditions
- Minimal 'Trail'

omnifloat™



- Delicate Contact
- Service Kits
- Wet & Dirty Conditions
- High Temperature

omniwheel™



- Driven Conveying
- Fast Directional Change
- Irregular Shapes
- Wet & Dirty Conditions



Amcats PVT. LTD
 B20 / C111A, Punit Industrial Estate
 D10-11A, Thane Belapur Road
 Near Turbhe Rly Stn, Turbhe
 Navi Mumbai - 400 705



- +91-22-61464444
- +91-22-25564987
- sales@amcats.com
- www.omnitrack.in