

## 9500 OMNITRACK HEAVY DUTY BALL TRANSFER UNIT

Available Material Options			
Part #	Load Bearing Internal Materials	Ball Material	Casing Material & Finish
9500	AISI 52100	AISI 52100	AISI 1012 ZINC/ELECTROPHORETIC (BLACK)
9500A	AISI 52100	AISI 440	AISI 1012 ZINC/ELECTROPHORETIC (BLACK)
9500SS	AISI 440	AISI 440	AISI 304 - NATURAL

SPRING MATERIAL FOR ALL OPTIONS = LIGHTLY GREASED CARBON STEEL

### NOTES:

1. SUPPORTS A LOAD OF 23 Kg / 50 Lbs
2. 38 Kg / 84 Lbs LOAD AT MAXIMUM DEFLECTION

∅ 12.7 [0.5]

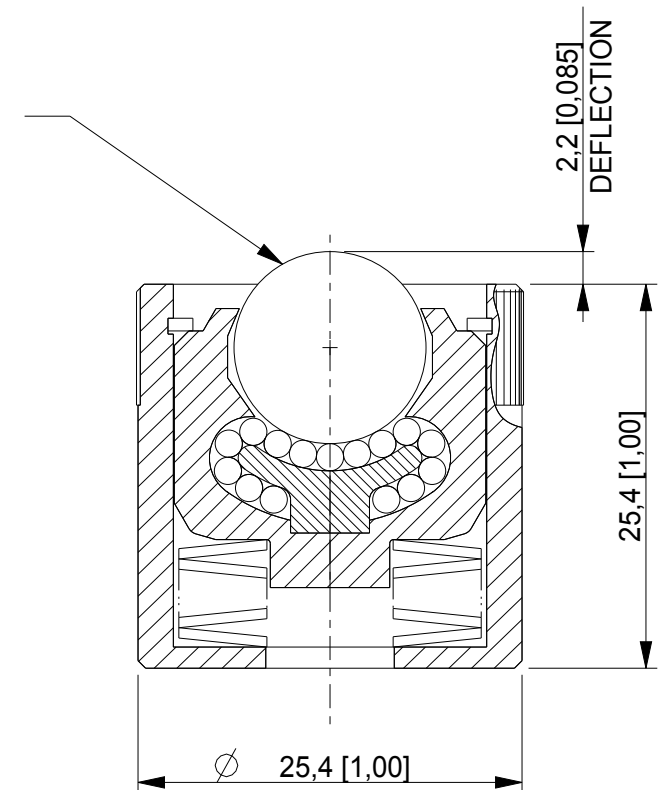

### REVISION # 03

ALL DIMENSIONS IN mm [inch]  
IF VIEWED AS PDF, DO NOT SCALE  
IF VIEWED AS DWG, SCALE 2 : 1  
TOLERANCE ± 0,25 [0.01]  
QMF 31 ISSUE 02: 09/01/2017

**OMNITRACK**  
RODBOROUGH COURT  
STROUD, GL5 3LR, ENGLAND

Telephone: +44 (0)1453 873 345  
Fax: +44 (0)1453 878 500  
[info @ omnitrack.com](mailto:info@omnitrack.com)  
[www.omnitrack.com](http://www.omnitrack.com)

THIS DOCUMENT CONTAINS OMNITRACK PROPERTY AND CONFIDENTIAL INFORMATION. IT IS LOANED FOR LIMITED PURPOSES ONLY AND REMAINS THE PROPERTY OF OMNITRACK. IT MAY NOT BE REPRODUCED IN WHOLE OR PART OR DISCLOSED TO THIRD PARTIES WITHOUT THE PRIOR WRITTEN CONSENT OF OMNITRACK. THE DOCUMENT IS TO BE RETURNED TO OMNITRACK UPON REQUEST AND IN ALL EVENTS UPON COMPLETION OF THE USE FOR WHICH IT WAS LOANED