



OMNI-DIRECTIONAL SOLUTIONS SINCE 1909

9501 OMNITRACK  
HIGH CAPACITY  
BALL TRANSFER UNIT  
REVISION # 01

Available Material Options			
Part #	Load Bearing Internal Materials	Ball Material	Casing Material & Finish
9501	AISI 52100	AISI 52100	AISI 1012 ZINC/ELECTROPHORETIC (BLACK)
9501A	AISI 52100	AISI 440	AISI 1012 ZINC/ELECTROPHORETIC (BLACK)
9501SS	AISI 440	AISI 440	AISI 304 - NATURAL

SPRING MATERIAL FOR ALL OPTIONS = LIGHTLY GREASED CARBON STEEL

NOTES:

1. SUPPORTS A LOAD OF 12 Kg / 26 Lbs
2. 42 Kg / 101 Lbs LOAD AT MAXIMUM DEFLECTION

∅ 12,7 [0.5]

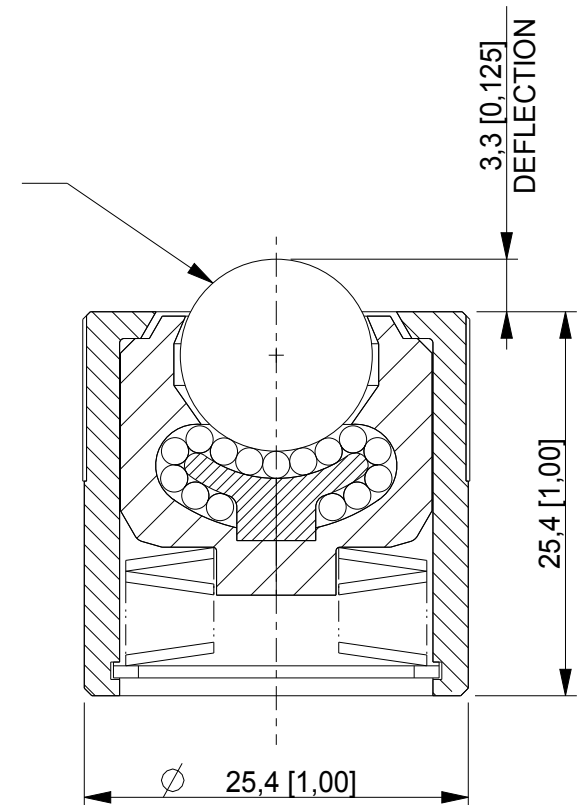

ALL DIMENSIONS IN mm [inch]  
IF VIEWED AS PDF, DO NOT SCALE  
IF VIEWED AS DWG, SCALE 2 : 1  
TOLERANCE ± 0,25  
QMF 31 ISSUE 01 : 22/06/2012

**OMNITRACK**  
RODBOROUGH COURT  
STROUD, GL5 3LR, ENGLAND

Telephone: +44 (0)1453 873 345  
Fax: +44 (0)1453 878 500  
**info @ omnitrack.com**  
**www.omnitrack.com**

THIS DOCUMENT CONTAINS OMNITRACK PROPERTY AND CONFIDENTIAL INFORMATION. IT IS LOANED FOR LIMITED PURPOSES ONLY AND REMAINS THE PROPERTY OF OMNITRACK. IT MAY NOT BE REPRODUCED IN WHOLE OR PART OR DISCLOSED TO THIRD PARTIES WITHOUT THE PRIOR WRITTEN CONSENT OF OMNITRACK. THE DOCUMENT IS TO BE RETURNED TO OMNITRACK UPON REQUEST AND IN ALL EVENTS UPON COMPLETION OF THE USE FOR WHICH IT WAS LOANED