

R15-400
OMNITRACK
BALL TRANSFER RAIL

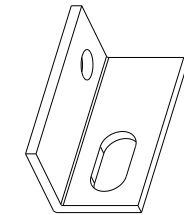

FIXING BRACKET - RB1
OPTIONAL 50x25mm
BRACKET MADE FROM
3mm THICK ANGLE

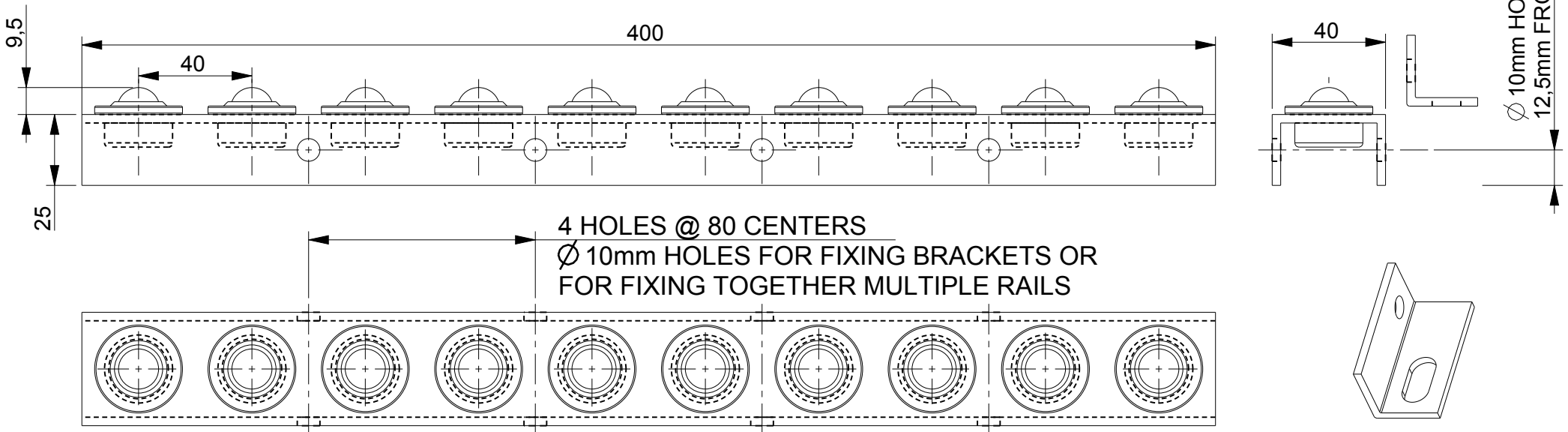
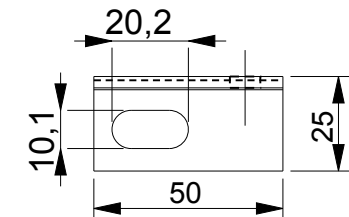

Material Options			
Part Number	Bar Material	Ball Material	Load Rating
R15-400	AISI 1012 Electrophoretic (Black)	AISI 52100	600 kg / 1300 lbs
R15-400A	AISI 1012 Electrophoretic (Black)	AISI 420	600 kg / 1300 lbs
R15-400D	AISI 1012 Electrophoretic (Black)	Acetal (POM)	100 kg / 220 lbs
R15-400SS	AISI 304 - Natural	AISI 420	400 kg / 900 lbs

REVISION # 01

ALL DIMENSIONS IN mm [inch]
IF VIEWED AS PDF, DO NOT SCALE
IF VIEWED AS DWG, SCALE x : x
TOLERANCE ± 0,25 [0,01]
QMF 31 ISSUE 02 : 09/01/2017

OMNITRACK
RODBOROUGH COURT
STROUD, GL5 3LR, ENGLAND

Telephone: +44 (0)1453 873 345
Fax: +44 (0)1453 878 500
info@omnitrack.com
www.omnitrack.com

THIS DOCUMENT CONTAINS OMNITRACK
PROPERTY AND CONFIDENTIAL INFORMATION.
IT IS LOANED FOR LIMITED PURPOSES ONLY
AND REMAINS THE PROPERTY OF OMNITRACK.
IT MAY NOT BE REPRODUCED IN WHOLE
OR PART OR DISCLOSED TO THIRD PARTIES
WITHOUT THE PRIOR WRITTEN CONSENT OF
OMNITRACK. THE DOCUMENT IS TO BE
RETURNED TO OMNITRACK UPON REQUEST
AND IN ALL EVENTS UPON COMPLETION OF THE
USE FOR WHICH IT WAS LOANED