



OMNI-DIRECTIONAL SOLUTIONS SINCE 1909

**T20 OMNITRACK
HIGH CAPACITY SPRING LOADED
BALL TRANSFER BAR**
REVISION # 01

Available Material Options			
Part #	Load Bearing Internal Materials	Ball Material	Casing Material & Finish
T20	AISI 52100	AISI 52100	AISI 1012 ZINC/ELECTROPHORETIC (BLACK)

**BAR SUPPORTS A LOAD OF 224 Kg / 492.8 Lbs
LOAD AT MAX DEFLECTION 352 Kg / 774.4 Lbs**

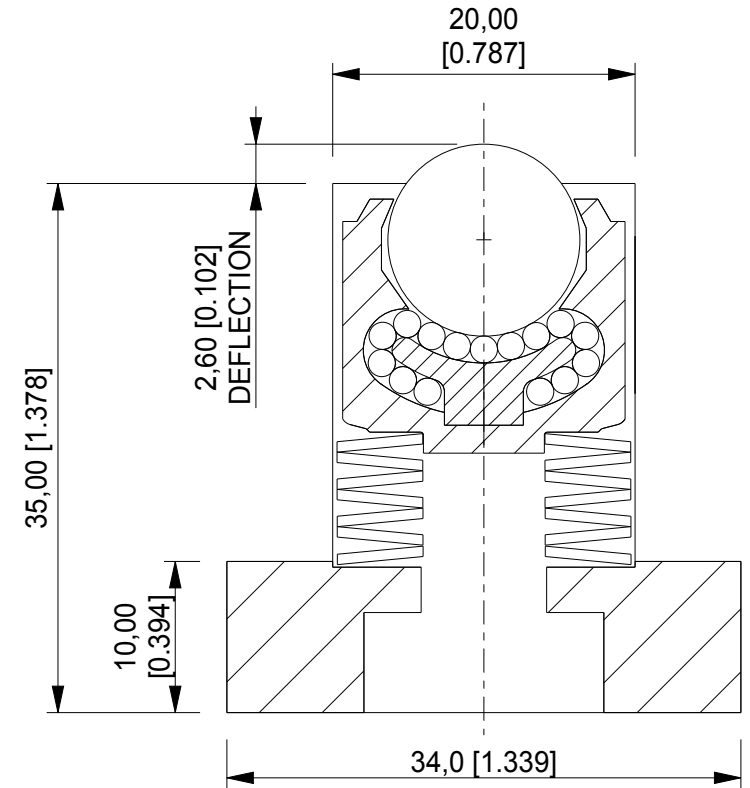
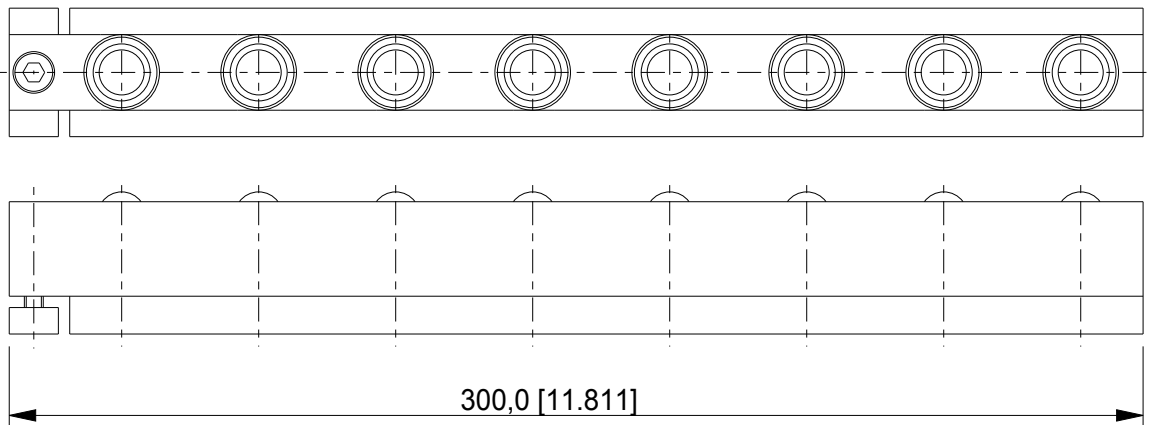

SECTION THROUGH INTERNAL BALL UNIT
SCALE 2:1

**OTHER SIZES AVAILABLE - CONTACT TECHNICAL SUPPORT
FOR CUSTOM MADE BALL TRANSFER BARS**

ALL DIMENSIONS IN mm [inch]
IF VIEWED AS PDF, DO NOT SCALE
IF VIEWED AS DWG, SCALE 1 : 2
TOLERANCE ± 0,25
QMF 31 ISSUE 01 : 22/06/2012

OMNITRACK
RODBOROUGH COURT
STROUD, GL5 3LR, ENGLAND

Telephone: +44 (0)1453 873 345
Fax: +44 (0)1453 878 500
info @ omnitrack.com
www.omnitrack.com

THIS DOCUMENT CONTAINS OMNITRACK
PROPERTY AND CONFIDENTIAL INFORMATION.
IT IS LOANED FOR LIMITED PURPOSES ONLY
AND REMAINS THE PROPERTY OF OMNITRACK.
IT MAY NOT BE REPRODUCED IN WHOLE
OR PART OR DISCLOSED TO THIRD PARTIES
WITHOUT THE PRIOR WRITTEN CONSENT OF
OMNITRACK. THE DOCUMENT IS TO BE
RETURNED TO OMNITRACK UPON REQUEST
AND IN ALL EVENTS UPON COMPLETION OF THE
USE FOR WHICH IT WAS LOANED